

SERVICE BULLETIN



Service Bulletin No.: DA20-73-05 Rev 0

Date Issued: August 12, 2011

Title: Introduction of a new Fuel Pump Assembly

Page: 1 of 7

1. **ATA Code:** 7300
2. **Effectivity:** All DA20-A1 Aircraft equipped with Rotax 912 F3 and 912 S3 engines.
3. **General:** This service bulletin addresses introduction of a fuel pump assembly P/N 893110 / P/N 893114 on ROTAX 912 engines via ROTAX Service Instruction SI-912-20 R5.
4. **Compliance:** Required if fuel pump assembly P/N 893110 / P/N 893114 installed on ROTAX 912 engine.
5. **Approval:** Engineering data referenced or contained in this service bulletin is approved as part of the type design.
6. **Labour:** Approximately 2 hours will be required to accomplish this service bulletin.

This estimate is for direct labor performed by a technician and it does not include setup, planning, familiarization or tools acquisition.

7. **Material:** In addition to parts defined by ROTAX Service Instruction SI-912-20 R5 the following materials are required to accomplish this service bulletin:

Part Number	Description	Qty.
F-5500-A	Tubing 0.25"IDx0.375"OD	780mm (30.75")
2650-6	Stratoflex Fire Sleeve	640mm (25.25")
5027	Stratoflex Fire Sleeve End Dip	A/R
210-248	Miniature Barbed Tee (Nylon)	1
MS3367-5-9	Self locking cable tie	5
PLT4S-M-30	Self locking cable tie	1
CSCS – M	Spacer, 90°	1
MS21919WDG12	Loop Clamp	2
MS21919WDG10	Loop Clamp	2
MS21042-3	Nut	2
AN3-4A	Bolt	2
NAS1149F0332P	Washer, Plain	4

The above material may be ordered as kit DA20-73-05-AMK1.
(See also referenced documents)

SERVICE BULLETIN



Service Bulletin No.: DA20-73-05 Rev 0

Date Issued: August 12, 2011

Title: Introduction of a new Fuel Pump Assembly

Page: 3 of 7

- 10.1.10 Close the fuel shut off valve.
- 10.1.11 Disconnect the battery. Refer to AMM, Chapter 24-31.
- 10.1.12 Remove hose used for flushing fuel system components.
- 10.1.13 Connect the fuel outlet hose in accordance with Rotax Service Instruction SI-912-020 R5.

10.2. Drain Tube Installation

- 10.2.1 Assemble Drain Tube as shown in Figure 1.
- 10.2.2 Install one end of the Drain Tube Assembly onto the drain fitting on the mechanical fuel pump. Route the Drain Tube Assembly inboard of the cooling air intake and outboard of the right side exhaust risers and coolant pipes. Secure the Drain Tube Assembly to the engine mount using loop clamps as shown in Figure 2.
CAUTION:
The drain tube should be installed without kinks or tight bends. It must provide a continuous base slope toward the Vent Tube.
- 10.2.3 Cut existing fuel drain hose 30 mm ($1 \frac{3}{16}$) above Vent Tube and install supplied barbed tee fitting as shown on Figure 3.
- 10.2.4 Connect Fuel Pump Drain Tube to barbed tee.
- 10.2.5 Secure all drain tube connections with self locking cable ties (Figure 2).
- 10.2.6 Secure Fuel Pump Drain Tube to cooling air intake with two cable ties and 90° Spacer as shown in Figure 2.

SERVICE BULLETIN



Service Bulletin No.: DA20-73-05 Rev 0

Date Issued: August 12, 2011

Title: Introduction of a new Fuel Pump Assembly

Page: 4 of 7

10.3. Final Tasks

- 10.3.1 Connect the battery. Refer to AMM Chapter 24-31.
- 10.3.2 Open the fuel shut off valve.
- 10.3.3 Perform fuel leaks check and foreign objects inspection.
- 10.3.4 Install the engine cowlings.
- 10.3.5 Perform engine test run. Refer to AMM, Chapter 05-20.
- 10.3.6 Make an entry of work performed in aircraft technical documentation as required.

11. Figures:

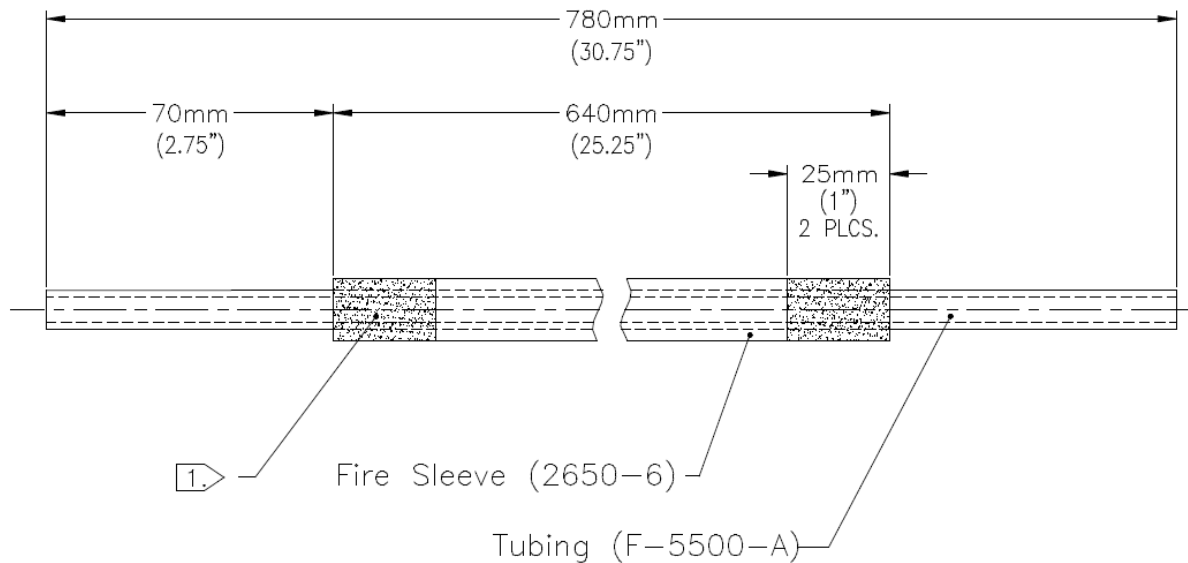

- 1. DIP TWICE EACH END OF STRATOFLEX FIRE SLEEVE INTO CONTAINER WITH STRATOFLEX FIRE SLEEVE END DIP P/N 5027 BEFORE ASSEMBLY. ALLOW SEALANT TO DRY BETWEEN APPLICATIONS.

Figure 1 – Drain Tube Assembly

SERVICE BULLETIN



Service Bulletin No.: DA20-73-05 Rev 0

Date Issued: August 12, 2011

Title: Introduction of a new Fuel Pump Assembly

Page: 5 of 7

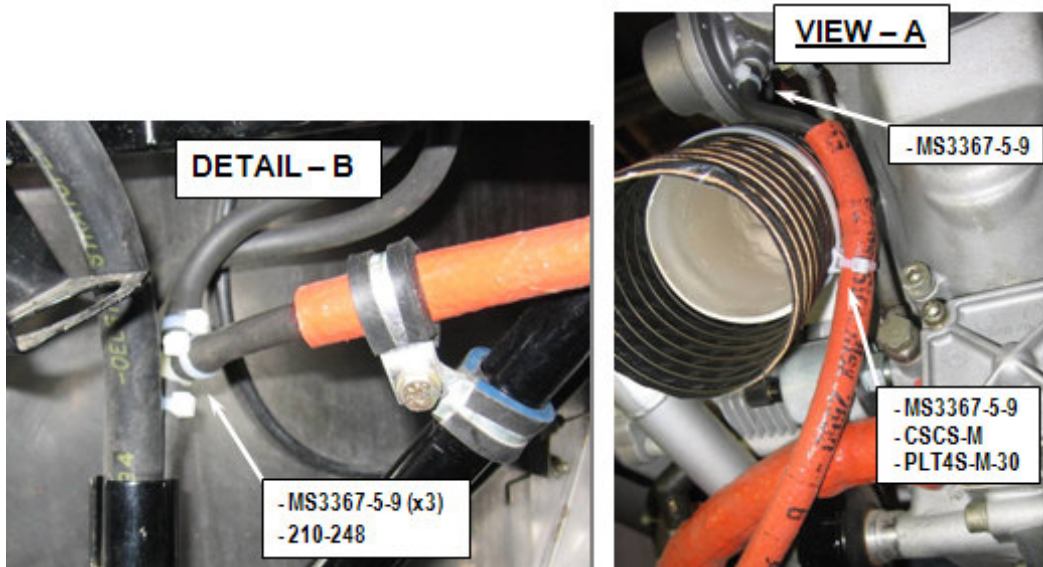
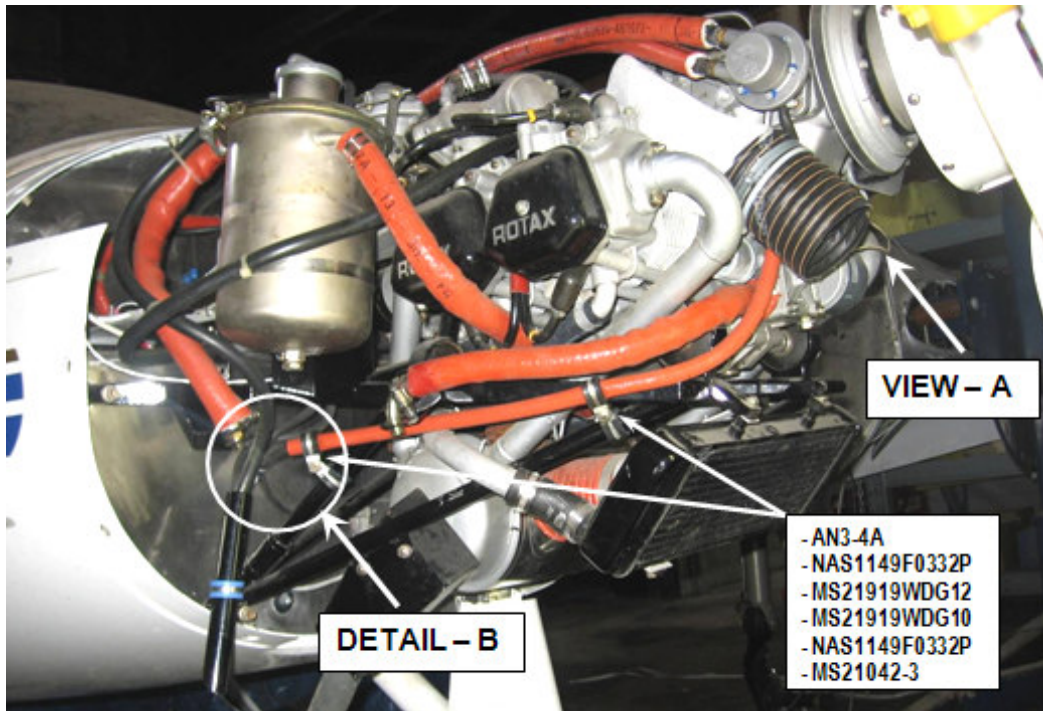

Figure 2 – Drain Tube Installation

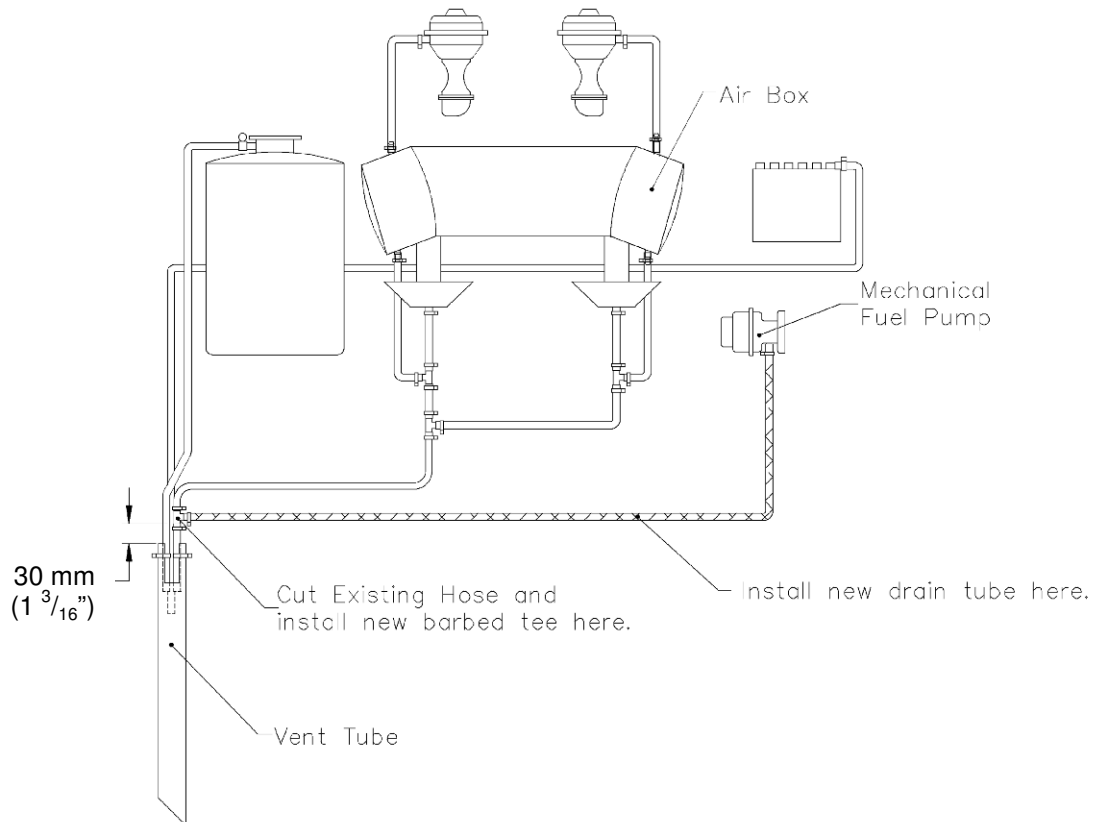

Figure 3 – Drain Tube Installation (Schematic)

SERVICE BULLETIN



Service Bulletin No.: DA20-73-05 Rev 0

Date Issued: August 12, 2011

Title: Introduction of a new Fuel Pump
Assembly

Page: 7 of 7

12. Weight and Balance:

The weight increases by 0.27kg (0.6Lbs);
Moment Arm -0.686m (-27") from the reference datum.

13. Labor Credit:

None

14. Availability:

Contact Diamond Aircraft Industries Inc..

To obtain satisfactory results, procedures specified in this service bulletin must be accomplished in accordance with accepted methods and current government regulations. Diamond Aircraft Industries Inc. cannot be responsible for the quality of work performed in accomplishing the requirements of this service bulletin. Diamond Aircraft reserves the right to void continued warranty coverage in the area affected by this Service Bulletin if it is not incorporated.

If you no longer own the aircraft to which this service bulletin applies, please forward it to the current owner and send the name of the current owner to Diamond Aircraft Industries, Inc., at the address below

Diamond Aircraft Industries Inc. 1560 Crumlin Sideroad, London, Ontario, Canada N5V 1S2

Phone: (519) 457-4041 Fax: (519) 457-4045

COPYRIGHT 2011