

SERVICE BULLETIN

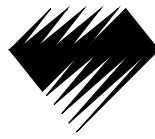

Diamond
AIRCRAFT

Service Bulletin No.: DA20-92-01, Rev. 0

Date Issued: May 10, 1996

Title: Certification, German Import Requirements

Page: 1 of 2

1. **ATA Code:** Not Applicable
2. **Effectivity:** All DA 20 Katanas, S/N 10002 and subsequent, for operation under German registry.
3. **General:** This bulletin describes modifications and equipment required for aircraft operation under German registry.
4. **Compliance:** Prior to issue of LBA Certificate of Airworthiness.
5. **Approval:** Data referenced or contained in this bulletin is LBA approved.
6. **Labor:** 2 Man-hours.
7. **Material:** German Placards (in accordance with Doc. No. DA202-D), Fuel Pipette (ref. P/N 20-1200-02-00).
8. **Special Tools:** None
9. **References:** Flight Manual Doc. No. DA202-D, LBA Type Certificate 1099.

10. Accomplishment Instructions:

10.1 Placards

- 10.1.1 All German language placards must be installed in place of original English placards, as per the Flight Manual, Doc. No. DA202-D, Section 2-15.

10.2 Fireproof Data Placard

- 10.2.1 Data Plate (ref. P/N 20-1120-01-12) must be engraved or stamped with the aircraft Serial Number, the year of manufacture and German registration.
- 10.2.2 The data plate must be permanently installed (i.e. blind rivets) in the location shown in Figure 1, page 2.

10.3 Fuel Pipette

- 10.3.1 All German registered aircraft must be equipped with the fuel pipette (ref. P/N 20-1200-02-00).

10.4 Flight Manual

- 10.4.1 Verify, that the Flight Manual, Doc. No. DA202-D, contains the serial number specific data (Equipment Configuration, Weight and Balance data, Supplements).
- 10.4.2 Install German language Flight Manual, Doc. No. DA202-D, in the aircraft.

10. Accomplishment Instructions cont'd:

10.5 Required Equipment

- 10.5.1 **GENERAL.** It is the responsibility of the operator to ensure that the aircraft is equipped as required by applicable German regulations for its intended types of operation.
- 10.5.2 **BASIC EQUIPMENT.** The Flight Manual (ref. Doc. No. DA202-D) specifies the minimum equipment for safe operation of the DA-20 Katana.
- 10.5.3 **COM/NAV EQUIPMENT.** Additional required COM/NAV equipment is specified in the "Verordnung über die Flugsicherungs-ausrüstung der Luftfahrzeuge (FSAV)", depending on the type of operation (e.g.: VFR, CVFR, Flights "over the top").
- 10.5.4 **CABIN EQUIPMENT.** For TP3 operations, the aircraft must be equipped with a first aid kit, an emergency axe, and a fire extinguisher. This equipment must meet applicable regulations and must be installed in an approved manner.

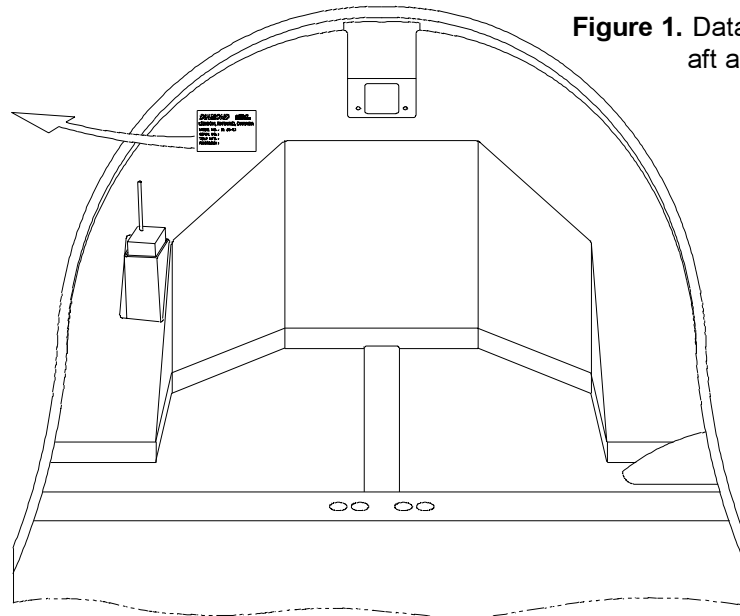
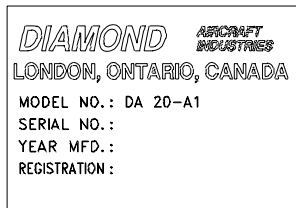

Figure 1. Data Plate Location (Looking aft at the B-bulkhead).

11. Weight and Balance: Not Applicable

12. Electrical Load Data: Not Applicable

13. Credit: None

To obtain satisfactory results, procedures specified in this Service Bulletin must be accomplished in accordance with accepted methods and current government regulations. Diamond Aircraft Industries Inc. cannot be responsible for the quality of work performed in accomplishing the requirements of this Service Bulletin.