

# SERVICE BULLETIN

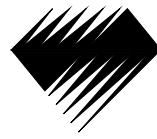

**Diamond**  
AIRCRAFT

Service Bulletin No.: DA20-24-02, Rev. 0

Date Issued: January 8, 1996

Title: DC Generation, ( Improved Generator Grounding )

Page: 1 of 2

1. **ATA Code:** 2430
2. **Effectivity:** All DA 20 Katana Aircraft up to and including serial number 10045.
3. **General:** The ground return for the generator and generator fail indication is currently supplied through the generator mounting brackets. The addition of a chassis grounding wire from the generator directly to the engine is required to ensure adequate grounding.
4. **Compliance:** Incorporation of this Service Bulletin is highly recommended by Diamond Aircraft and should be accomplished at the operator's earliest opportunity.
5. **Approval:** Engineering data referenced or contained in this bulletin is Transport Canada approved.
6. **Labor:** Approximately 0.5 man hour.
7. **Material:**

<u>Description</u>	<u>Part Number</u>
Ground wire	24313A8N
Lock washer	945-751
Bolt	DIN933M6x20

Above material may be ordered by submitting a purchase order to Diamond Aircraft, Customer Support for Service Bulletin Material Kit, part number MK20-24-02
8. **Special Tools:** None
9. **References:** DA20 Katana Parts Manual  
Figure 1.
10. **Accomplishment Instructions**
  - 10.1 Remove upper and lower engine cowlings to gain access..
  - 10.2 Ensure all electrical contacts areas are clean.
  - 10.3 Remove lower case bolt from generator. Place the lower case bolt through the grounding wire ring terminal and re-install the bolt into the generator housing.
  - 10.4 Place the supplied bolt and lock washer through the grounding wire ring terminal and install in the # 2 cylinder head casting threaded hole located on the top forward outboard part of the cylinder.
  - 10.5 Route the wire clear of the exhaust pipe.
  - 10.6 Ensure the engine compartment is clear of foreign materials and re-install the engine cowlings.

# SERVICE BULLETIN

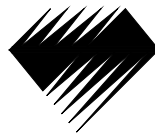

**Diamond**  
AIRCRAFT

Service Bulletin No.: DA20-24-02, Rev. 0

Date Issued: January 8, 1996

Title: DC Generation, ( Improved Generator Grounding )

Page: 2 of 2

11. Weight and Balance: Not Applicable

12. Electrical Load Data: Not Applicable

13. Credit: None

Figure 1 (Ref. DAI Drawing #20-2400-06-01, Rev. b)

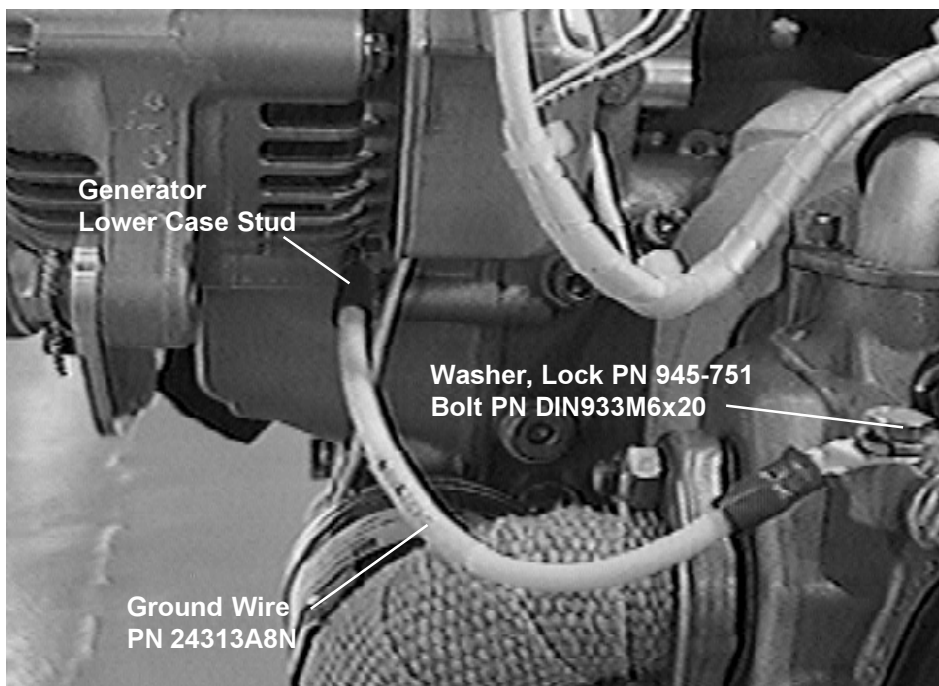

*To obtain satisfactory results, procedures specified in this service information letter must be accomplished in accordance with accepted methods and current government regulations. Diamond Aircraft Industries Inc. cannot be responsible for the quality of work performed in accomplishing the requirements of this service information letter.*

Diamond Aircraft Industries Inc. 690 Crumlin Sideroad, London, Ontario, Canada N5V 1S2  
Phone: (519) 457-4000 Fax: (519) 457-4037

COPYRIGHT 1995