

SERVICE BULLETIN



Service Bulletin No.: DAC1-53-01 Rev 2

Date Issued: March 23, 2009

Title: Spar Bridge Gusset Reinforcement

Page: 1 of 7

- 1. ATA Code:** 5300
- 2. Effectivity:** DA20-C1 Aircraft S/N C0001 to C0018, C0020 to C0026, C0029 to C0067, C0069 to C0078, C0080 to C0084, C0086 to C0531, C0533, C0534, C0536 to C0539, C0541, and C0544.
- 3. General:** Small delaminations in the upper aft corners of the spar bridge have been reported on some aircraft. This service bulletin addresses the bonding of four (4) reinforcement gussets to the area in order to limit delamination growth.
- 4. Compliance:** Compliance with this service bulletin is recommended.
- 5. Approval:** Engineering data referenced or contained in this service bulletin is approved as part of the type design.
- 6. Labour:** Approximately 6 hours will be required to accomplish this service bulletin. Approximately 2 hours will be required if performed at a 1000 hr inspection.

This estimate is for direct labour performed by a technician and it does not include setup, planning, familiarization, cure time, part fabrication or tool acquisition.

7. Material:	Part Number	Description	Qty
	22-5310-91-00	Spar Bridge Gusset 1, Layup	2
	22-5310-92-00	Spar Bridge Gusset 2, Layup	2

Materials required but not supplied: procure locally.

L160	Scheufler L160 Resin	A/R
H163	Scheufler H163 Hardener	A/R
L285	Scheufler L285 Resin	A/R
H286	Scheufler H286 Hardener	A/R
Cotton Flocks	Cotton Fibers	A/R
Scotchlite K20	Microballoons	A/R
Aerosil	Filler	A/R
N/A	80 Grit Sandpaper	A/R

Note: DA20-C1 S/N C0001 to C0185 and C0200 and up use L160 system.
DA20-C1 S/N C0186 to C0199 use L285 system.

- 8. Special Tools:** Heat gun.
- 9. References:** DA20-C1 Aircraft Maintenance Manual (AMM), Document # DA201-C1.
- 10. Accomplishment Instructions:**
- 10.1** Place a clean blanket over seats to protect from damage while work is being performed.
- 10.2** Remove the LH & RH baggage tray and baggage floor from the aircraft as per AMM Chapter 25-10-00.

- 10.3 Drain fuel from system and remove the fuel tank as per AMM Chapter 28-10-00.
- 10.4 Mask off all components in the surrounding area to keep dust away and ensure all fuel lines are properly capped.
- 10.5 Prepare area shown in Figure 1 / Figure 2 for bonding by abrading surface with 80 grit sandpaper. **Do not sand into the glass cloth.** Clean surface with isopropanol and wipe off immediately.
- 10.6 Inspect outer upper AFT corners of spar bridge for delamination as per AMM Chapter 05-20-00.
- 10.7 If delamination is present mark out the contour with a fine tip permanent marker. **If the area of delamination exceeds 1800 mm² (2.79 in²), do not proceed with this service bulletin and contact Diamond Aircraft Industries Inc.**
- 10.8 Dry fit gussets into place to ensure paste gap does not exceed 8 mm. Location of gussets shown in Figure 3. Mask off area around bonding flanges once position has been set.
- 10.9 Ensure any wiring near bonding area is temporarily secured away with the use of cable ties.
- 10.10 Mix resin and paste as per Appendix A.
- 10.11 Remove peel ply from gussets.
- 10.12 Wet all bonding surfaces with mixed resin.
- 10.13 Apply paste to gusset bonding flanges. Paste depth determined by bond gap during dry fit. Contour paste higher in joint center to avoid air pockets. **Do not apply paste to gusset radii.**
- 10.14 Fit gussets to appropriate location and orientation as shown in Figure 3. Clean excess paste as it is squeezed out. **Ensure all paste squeeze out is cleaned from gusset radii and upper aft spar bridge corner. The area must be fully visible for inspection. See Figure 4.**
- 10.15 Immobilize the parts until the pre-cure is complete (approximately 24 hours at 20°C, 68°F). It may be necessary to temporarily support the lower gussets during this time to prevent shifting while the paste is curing. Do not disturb the bonded parts until the full pre-cured duration has been reached.
- 10.16 Post-cure the entire repair area as per Appendix B. Do not disturb the bonded parts until the full post-cured duration has been reached.
- 10.17 Remove any temporary fixtures used and clean area.

SERVICE BULLETIN



Service Bulletin No.: DAC1-53-01 Rev 2

Date Issued: March 23, 2009

Title: Spar Bridge Gusset Reinforcement

Page: 3 of 7

- 10.18** Reinstall the fuel tank and fuel lines as per AMM Chapter 28-10-00.
- 10.19** Reinstall the LH & RH baggage tray and baggage floor as per AMM Chapter 25-10-00.
- 10.20** Make a log book entry stating that this service bulletin has been incorporated.

11. Weight and Balance:

This installation adds 0.680 kg (1.50 lbs) at a moment arm of +0.565 m. (+22.24 in).

12. Availability:

Contact Diamond Aircraft Industries Inc.

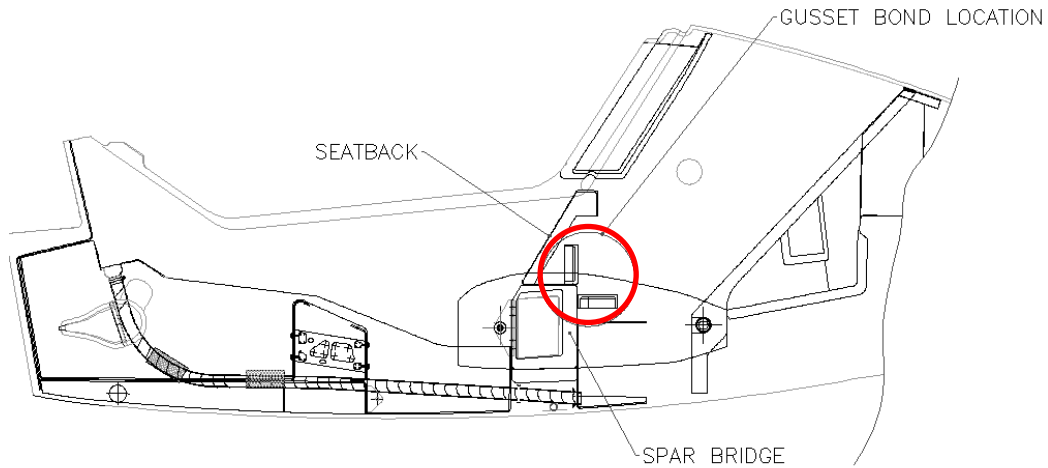

Figure 1 – Reference Repair Location

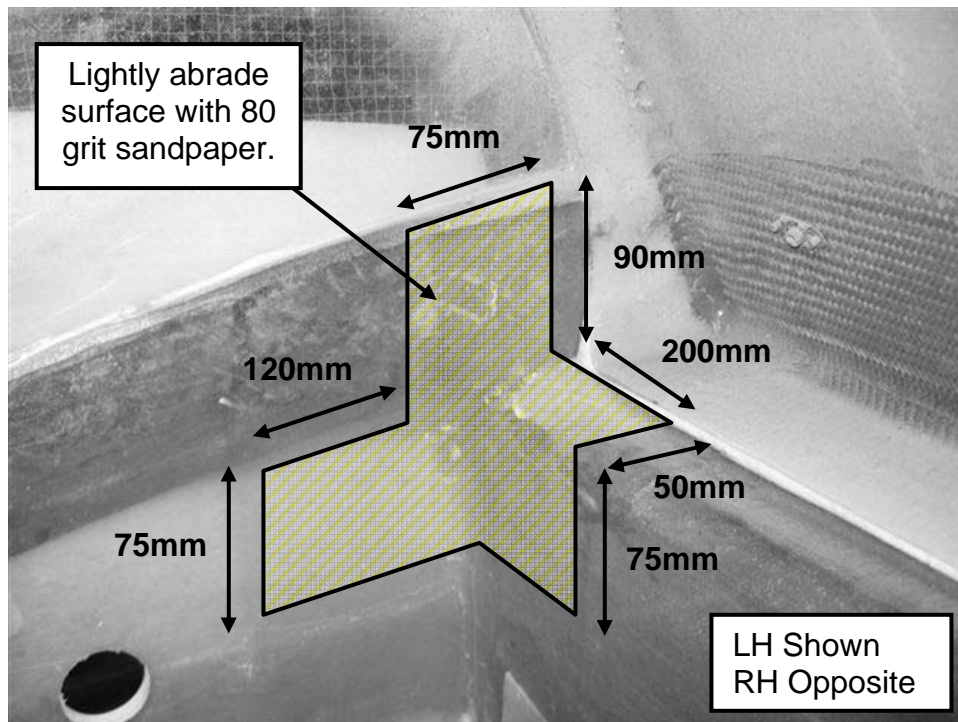

Figure 2 – Gusset Bonding Area – View Of LH Upper AFT Spar Bridge

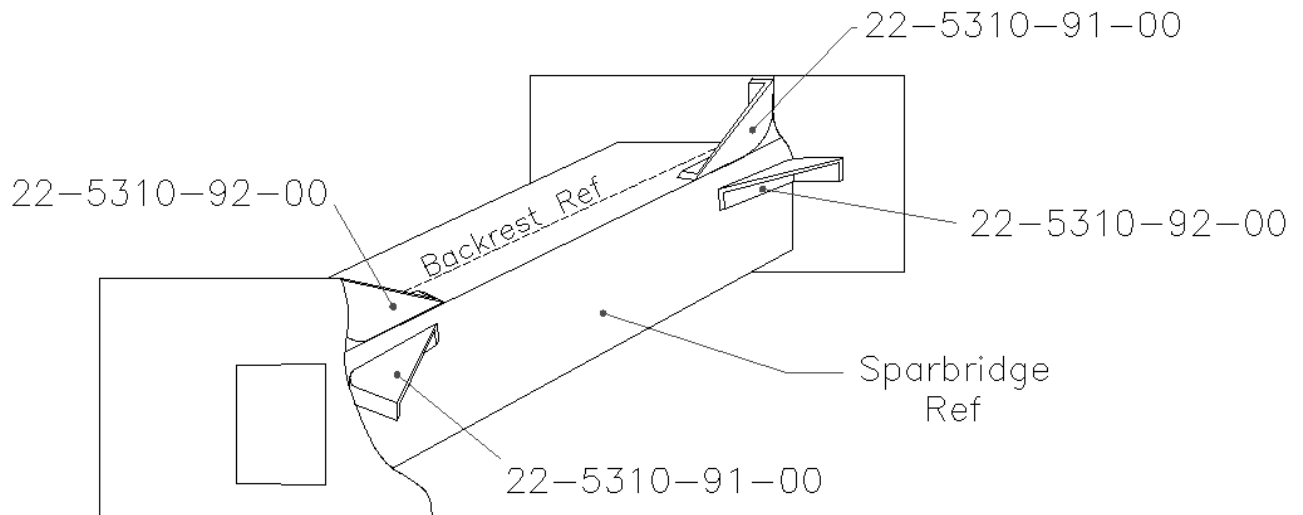

Figure 3 – Gusset Orientation

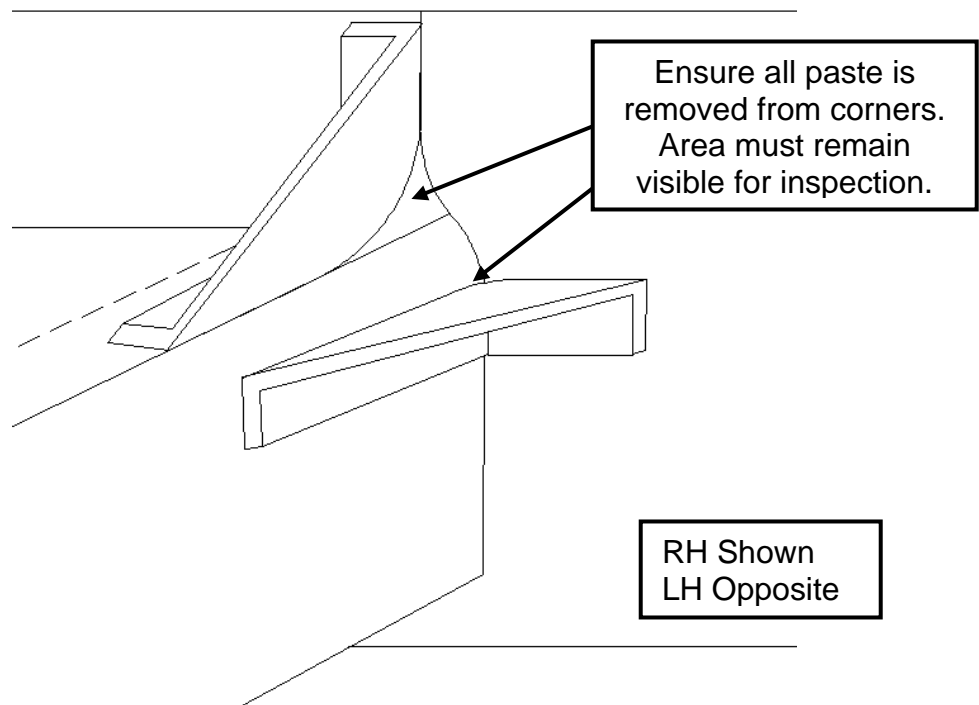

Figure 4 – Paste Cleanup

Appendix A: Resin and Paste Mix

L160/H163 System

Mixed Resin:

Resin: L160 (100 parts by weight)

Hardener: H163 (28 parts by weight)

Paste:

Refer to table below for recommended mixture.

Table 1: Paste Mixture

MATERIAL	WEIGHT IN GRAMS								
	50	100	150	200	250	300	350	400	450
L160/H163 Mixed Resin	50	100	150	200	250	300	350	400	450
Cotton Flocks	5	10	15	20	25	30	35	40	45
Aerosil	1.5	3	4.5	6	7.5	9	10.5	12	13.5
Microballoons	2	4	6	8	10	12	14	16	18

Quantity of microballoons and aerosil may be varied to change paste consistency. The total mix of fillers must not exceed 20% by volume.

L285/H286 System

Mixed Resin:

Resin: L285 (100 parts by weight)

Hardener: H286 (40 parts by weight)

Paste:

Refer to table below for recommended mixture.

Table 2: Paste Mixture

MATERIAL	WEIGHT IN GRAMS								
	50	100	150	200	250	300	350	400	450
L285/H286 Mixed Resin	50	100	150	200	250	300	350	400	450
Cotton Flocks	6	11.5	17	23	29	34.5	40	46	52
Aerosil	1.4	2.8	4.2	5.5	6.9	8.3	9.7	11.1	12.5

Appendix B: Local Post-Cure Of Repairs

Composite repairs must be post cured to obtain the necessary structural properties:

L160/H163

Post cure temperature: 60° ±5°C (140° ±9°F)

Post cure time: 12 hours (May be divided into two 6 hour periods)

L285/H286

Post cure step 1: 65°C (149°F), for 6 hours

Post cure step 2: 80°C (176°F), for 14 hours (May be divided into two 7 hour periods)

Construct a temporary enclosure around the repair to entrap heat. This can be made of corrugated cardboard, wood, heavy blankets, etc. Heat resistant coroplast is highly recommended.

Use a heat gun to heat the ambient air around the repair area. Do not point the heat gun directly at the composite material. Use a thermocouple probe to measure the surface temperature at the repair. Adjust the heat gun to maintain target temperature ±5°C (±9°F).