

SERVICE BULLETIN



Service Bulletin No.: DA20-72-02 Rev 0

Date Issued: 22 August 2006

Title: DA20-A1 – Evans NPG+ Coolant

Page: 1 of 2

- 1. ATA Code:** 7200
- 2. Effectivity:** DA20-A1 Aircraft
- 3. General:** This service bulletin addresses use of Evans NPG+ coolant in compliance with Rotax Mandatory Service Bulletin SB-912-043. Evans NPG+ is a waterless coolant that provides improved protection against overheating of the cylinder heads. Installation on aircraft with 100 hp Rotax 912S3 engines includes shortening of the fixed baffle on the oil cooler.
- 4. Compliance:** Mandatory
- 5. Approval:** Engineering data referenced or contained in this service bulletin is approved as part of the type design.
- 6. Labor:** Approximately 1 hour will be required to accomplish this service bulletin.
This estimate is for direct labor performed by a technician and it does not include setup, planning, familiarization, cure time, part fabrication or tool acquisition.
- 7. Material:**
- | Part Number | Description | Qty |
|-------------|--|----------------|
| 898490 | Warning Label, Evans NPG+ | 1 |
| Evans NPG+ | Waterless Coolant
(Procure locally) | 3.78 l (1 USG) |
- 8. Special Tools:** N/A
- 9. References:** DA20 Maintenance Manual, Document number DA201.
DA20 Flight Manual, Document number DA202.
Rotax Service Bulletin SB-912-043.
Maintenance Manual for ROTAX Engine Type 912

10. Accomplishment Instructions:

- 10.1 Remove upper and lower cowlings.
- 10.2 Completely drain coolant in accordance with Maintenance Manual.
- 10.3 Replace coolant with Evans NPG+.
- 10.4 Install Warning Label, Evens NPG+ on dispatch reservoir cap.

For Rotax 100 hp 912S3 engines only:

- 10.5 Loosen oil cooler fittings and remove air outlet baffle.
- 10.6 Trim 12mm (0.47”) off lower edge of air outlet baffle.
- 10.7 Reinstall air outlet baffle and tighten oil cooler fittings.

SERVICE BULLETIN



Service Bulletin No.: DA20-72-02 Rev 0

Date Issued: 22 August 2006

Title: DA20-A1 – Evans NPG+ Coolant

Page: 2 of 2

10.8 Run engine and ensure no leaks.

10.9 Install upper / lower cowl.

All aircraft:

10.10 Make the appropriate entry into the aircraft records.

11. Weight and Balance:

Weight and balance is not significantly affected by this Service Bulletin.

12. Availability:

Contact Diamond Aircraft.

To obtain satisfactory results, procedures specified in this service bulletin must be accomplished in accordance with accepted methods and current government regulations. Diamond Aircraft Industries Inc. cannot be responsible for the quality of work performed in accomplishing the requirements of this service bulletin. Diamond Aircraft reserves the right to void continued warranty coverage in the area affected by this service bulletin if it is not incorporated. If you no longer own the aircraft to which this service bulletin applies, please forward it to the current owner and send the name of the current owner to Diamond Aircraft Industries Inc. at the address below.

Diamond Aircraft Industries Inc. 1560 Crumlin Road, London, Ontario, Canada N5V 1S2
Phone: (519) 457-4041 Fax: (519) 457-4020

COPYRIGHT 2006

ROTAX

AIRCRAFT ENGINES

SERVICE BULLETIN

CHANGE OF COOLANT SPECIFICATION ON ROTAX® ENGINE TYPE 912 AND 914 (SERIES)

SB-912-043

SB-914-029

MANDATORY

Repeating symbols:

Please, pay attention to the following symbols throughout this document emphasizing particular information.

▲ **WARNING:** Identifies an instruction, which if not followed, may cause serious injury or even death.

■ **CAUTION:** Denotes an instruction which if not followed, may severely damage the engine or could lead to suspension of warranty.

◆ **NOTE:** Information useful for better handling.

1) Planning information

1.1) Engines affected

All versions of the engine type:

- 912 A all
- 912 F all
- 912 S all
- 914 F all

1.2) Concurrent ASB/SB/SI and SL

More to this Service Bulletin the following additional Service Bulletin must be observed and complied with:

- SB 912-039 / SB-914-025 "Modifications of the overflow bottle" current issue

1.3) Reason

In some instances conventional coolant (mixture ratio of 50% water and 50% antifreeze) can vaporize or boil before the maximum permissible cylinder head temperature is reached.

1.4) Subject

Change of coolant specification on ROTAX® engine type 912 (Series) and 914 (Series)

1.5) Compliance

- Within the next 100 operating hours, but at the latest by December 31, 2004, the newly specified coolant specifications are to be observed according to the following Instruction section 3 and applied.

▲ **WARNING:** Non-compliance with these instructions could result in engine damages, personal injuries or death.

1.6) Approval

The technical content of this document is approved under the authority of DOA Nr. MOT. JA-03.

1.7) Manpower

Engine installed in the aircraft - - - manpower time will depend on installation and thus, no estimate is available from the engine manufacturer.

1.8) Mass data

Change of weight - - - none

Moment of inertia - - - unaffected

d03276

SEPTEMBER 2004

Initial Issue

Copyright - ROTAX®

SB-912-043

SB-914-029

page 1 of 5

1.9) Electrical load data

No change

1.10) Software accomplishment summary

No change

1.11) References

In addition to this technical information refer to current issue of

- Operator's Manual (OM)
- Illustrated Parts Catalog (IPC)
- Maintenance Manual (MM)

1.12) Other publications affected

The following documentation must be replaced without any delay in accordance with this Service Bulletin and will become invalid.

Description	part no.	Issue	Date	Rev.	Chapter	Page
SL-912-009/914-008	n. a.		Dec. 2003	1		

The following documentations become effective with this Service Bulletin:

Description	part no.	Issue	Date	Rev.	Chapter	Page
Operator's Manual 912 Series	899370	0	1998 07 01	3		
Operator's Manual 914 Series	899641	0	1998 12 01	3		
Installation Manual 912 A	897860	0	1997 01 16	1		
Installation Manual 912 F	897796	0	1996 01 23	2		
Installation Manual 912 S	899376	0	1998 09 01	1		
Installation Manual 912 UL	897711	2	1997 03 26	1		
Installation Manual 914 F	897816	0	1996 05 10	1		

The replacement pages have to be included without delay into the respective documentation of the aircraft manufacturer.

1.13) Interchangeability of parts

Not affected

2) Material Information

2.1) Material - cost and availability

Prices and availability can be inquired about at:



07014

Evans Cooling Systems
www.evanscooling.com

USA, Central and South America, Australia, Asia and Canada:

Evans Cooling Systems Inc. Sales and Warehouse Office
PO BOX 434
Parkerford, PA 19457-0434, USA
Tel.: 001 610 323 3114
Fax: 001 610 970 0286
email: evans.npg@verizon.net
Contact Cathy or Dave

Europe, the Middle East and Africa:

RENOX S.n.c.
Via Bologna, 12
60019 Senigallia AN, Italy
Tel.: +39 071 792 7942
Fax: +39 071 791 0343
email: renox@renox.com
Contact Alex Priori

Northern Europe (The UK, Holland, Scandinavia etc)

GEARFOX UK
Charterhouse
106 Baker Street, Marylebone, London.
Tel: +44 20 7486 1970/1862
Fax: +44 20 7935 3268
email: dan.sargent@gearfox.co.uk
Contact: Dan Sargent

... or will be supplied on request by ROTAX[®] Authorized Distributors or their Service Center.
Contact your local ROTAX[®] Authorized Distributor as listed in the Operator's Manual or published on our official web-site at: www.rotax-aircraft-engines.com.

2.2) Company support information

None

2.3) Material requirement per engine

parts requirement:

Fig.no.	New part no.	Qty/engine	Description	Old part no.	Application
(1)	n.a.	as required	NPG+™ coolant liquid		cooling system

◆ NOTE: The required coolant quantity depends on the installation. In case of doubt contact your aircraft manufacturer.

2.5) Rework of parts

None

2.6) Special tooling/lubricant-/adhesives-/sealing compound - Price and availability

Price and availability will be supplied on request by ROTAX[®] Authorized Distributors or their Service Centers.
Parts requirement:

Fig.no.	part no.	Qty/engine	Description	Old part no.	Application
(1)	898490	1	warning sticker		radiator cap

3) Accomplishment / Instructions

Accomplishment

All the measures must be taken and confirmed by the following persons or facilities:

- ROTAX[®] -Airworthiness representative
- ROTAX[®] -Distributors or their Service Centers
- Persons approved by the respective Aviation Authority

▲ **WARNING:** Proceed with this work only in a non-smoking area and not close to sparks or open flames. Switch off ignition and secure engine against unintentional operation. Secure aircraft against unauthorized operation. Disconnect negative terminal of aircraft battery.

▲ **WARNING:** Risk of scalds and burns! Allow engine to cool sufficiently and use appropriate safety equipment while performing work

▲ **WARNING:** Should removal of a locking device (namely lock tabs, self-locking fasteners) be required when undergoing disassembly/assembly, always replace with a new one.

◆ **NOTE:** All work has to be performed in accordance with the relevant Maintenance Manual.

3.1) Coolant specification

The coolant specification is to be used according to the corresponding Operators Manual current issue, and according to the time schedules in section 1.5.

■ **CAUTION:** The safety-technical data of the coolant manufacturer must be observed!

3.2) Changing the coolant

(see fig. 1)

The coolant is to be replaced according to the Maintenance Manual, current issue.

■ **CAUTION:** The manufacturer's data for change/replacement, usage, and operation of the previously described coolant are to be observed. See Appendix section. 4.2.

◆ **NOTE:** On the radiator cap (3), to identify the new coolant, the warning label (2) is to be affixed so that the opening pressure data (4) is visible.

▲ **WARNING:** Water or water-containing coolant must **not** be added in any case to the cooling system!

- Restore aircraft to original operating configuration.

- Connect negative terminal of aircraft battery.

3.3) Test run

Conduct test run including ignition check and leakage test.

3.4) Summary

These instructions (section 3) have to be conducted in compliance with section 1.5.

Approval of translation to best knowledge and judgment - in any case the original text in the German language and the metric units (SI-system) are authoritative.

4) Appendix

4.1) Sticker

The following drawings should provide additional information: See fig. 1

- For new engine deliveries the sticker will be temporarily attached to the expansion tank.
- The sticker has to be affixed to the radiator cap in accordance to the aircraft manufacturer's instruction.

- 1 Expansion tank
- 2 Warning sticker
- 3 Radiator cap
- 4 Excess-pressure information

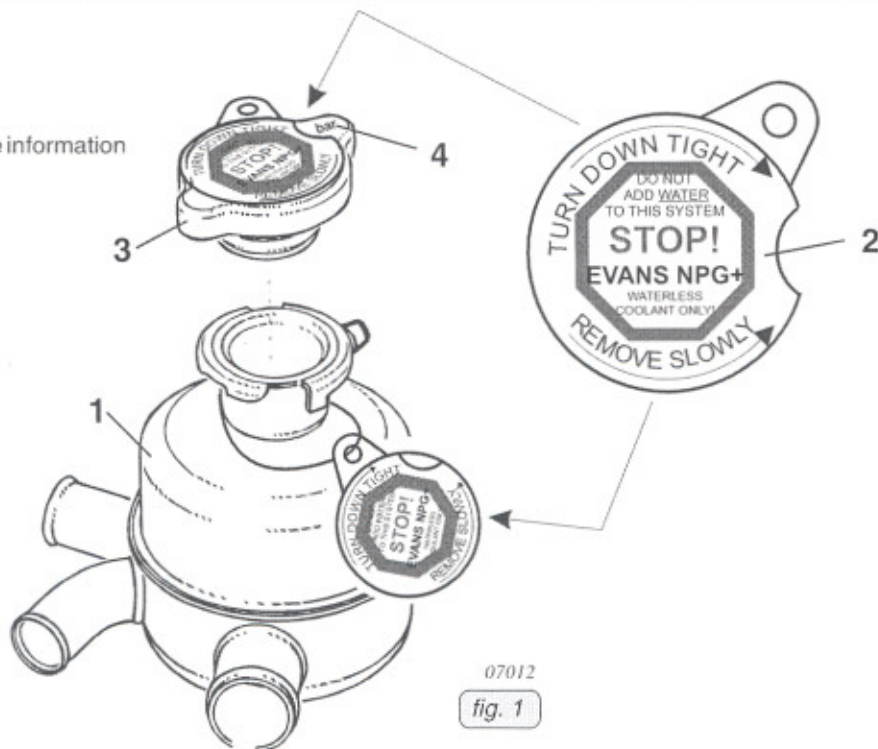

- ◆ NOTE: The illustrations in this document show the typical construction. They may not represent full detail or the exact shape of the parts which have the same or similar function. Exploded views are **not technical** drawings and are for reference only. For specific detail, refer to the current documents of the respective engine type.

4.2) Manufacturer Instruction

An NPG+ Instruction Manual is included in each scope of supply and also available on the official web-site of the manufacturer and includes detailed instructions about the operation and application of EVANS NPG+.

The coolant system of the ROTAX_® engine type 912/914 is designed for the operation with waterless coolant and therefore has not to be modified. The drain holes /venting holes should not be plugged.

4.2.1) Warning notices for operation with EVANS NPG+

- Water or water-containing coolant must **not** be added in **any case** to the cooling system!
- 3,6 % water or less in the system is acceptable and may be checked with a brix scale refractometer.
- Residual water, if present, will vent rapidly as steam. This could further lead, by too low cooling level, in a complete failure of the cooling system. Check coolant level in expansion tank (1) as per daily checks (see section 10.3.1 Operators Manual) or equivalent electronic warning system.
- If EVANS NPG+ coolant is not locally available, temporarily top off the system with propylene glycol antifreeze and be sure not to add water. Within 15 days the temporary coolant should be completely drained and the system refilled with EVANS NPG+ coolant.

- ◆ CAUTION: The above mentioned warning instructions are excerpts of the manufacturer published Instruction Manual, in any case the original text in the Instruction Manual is authoritative.