

SERVICE BULLETIN



Service Bulletin No.: DA20-79-07 Rev 0

Date Issued: Sept 18/03

Title: Oil Quantity Placard DA20-A1/DA20-100

Page: 1 of 2

1. **ATA Code:** 7900
2. **Effectivity:** Diamond Aircraft Model DA20 A1 aircraft.
3. **General:** Rotax has specified the use of a new oil dipstick that increases the oil capacity of the 912 A/F/S series engines (SB-912-040 R1). As a result, the oil capacity placard located on the oil reservoir cap must be replaced.
4. **Compliance:** At the next oil change or within the next 100 hours of operation, but at the latest by November 30,2003.
5. **Approval:** The engineering data referenced or contained in this service bulletin is approved as part of the type design.
6. **Labour:** Approximately 5 minutes will be required to accomplish this service bulletin.
This estimate is for direct labor performed by a technician and it does not include setup, planning, familiarization, cure time, part fabrication or tool acquisition.

7. Material:	Part Number	Description	Qty
	20-1120-00-24	Oil Quantity Placard	1

The above material is included with this service bulletin

8. **Special Tools:** No special tools required
9. **References:** Diamond Aircraft Maintenance Manual for the DA20 A1 Aircraft (Doc. DA201).
Rotax Service Bulletin SB-912-040 R1.

10. Accomplishment Instructions

- 10.1 Remove the existing placard from the oil reservoir cap.
- 10.2 Clean the surface of the oil cap, removing all traces of adhesive, oil or dirt.
- 10.3 Remove the foil backing from the new placard and apply the placard to the oil reservoir cap in the same location and orientation as the existing one.

11. **Weight and Balance:** This installation does not affect weight and balance

12. **Credit:** Not Applicable.

SERVICE BULLETIN



Service Bulletin No.: DA20-79-07 Rev 0

Date Issued: Sept 18/03

Title: Oil Quantity Placard DA20-A1/DA20-100

Page: 2 of 2

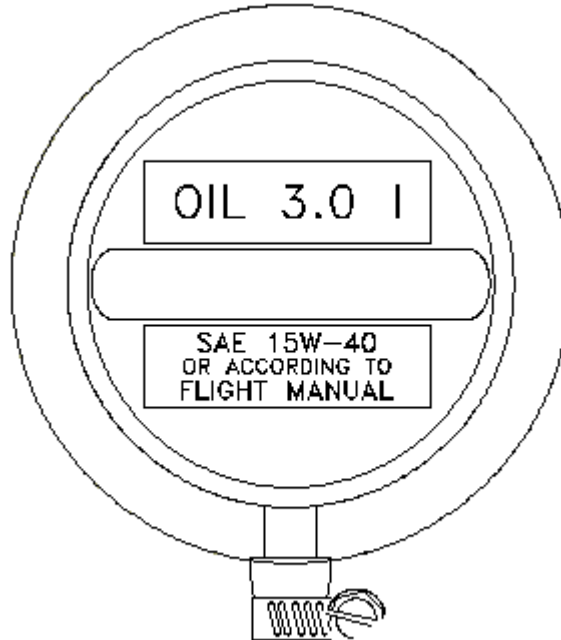

Figure 1
Old Placard

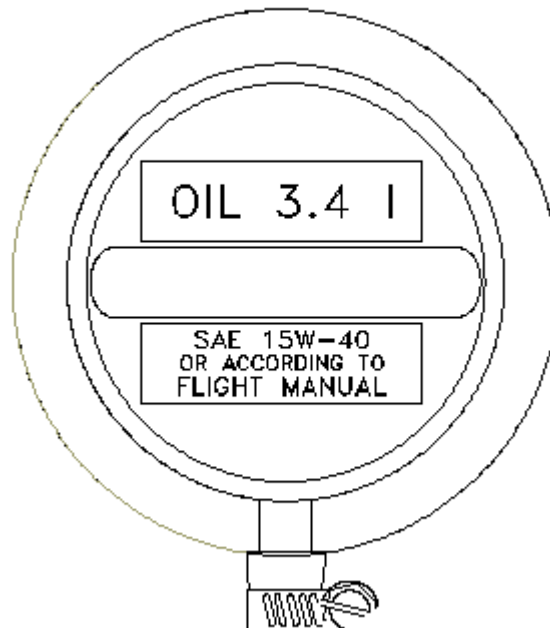

Figure 2
New Placard