

SERVICE BULLETIN



Service Bulletin No.: DA20-79-05 Rev 3

Date Issued: January 19, 2009

Title: DA20 A1 - Oil Line Retrofit - F3 Engine

Page: 1 of 6

- 1. ATA Code:** 7920
- 2. Effectivity:** DA20-A1 Aircraft
- 3. General:** This service bulletin addresses replacement of the existing oil hoses with stainless steel braided TSO hose assemblies. Mishandling, twisting, excessive bending, etc. can cause kinking or other damage to hoses, which if undetected can result in loss of oil flow and subsequent engine damage. The new style stainless steel braided hoses offer increased resistance to such damage.
- 4. Compliance:** Compliance with this service bulletin is recommended
- 5. Approval:** Engineering data referenced or contained in this service bulletin is approved as part of the type design.
- 6. Labour:** Approximately 1 hour will be required to accomplish this service bulletin. *This estimate is for direct labour performed by a technician and it does not include setup, planning, familiarization, cure time, part fabrication or tool acquisition.*

| 7. Material: | Part Number | Description | Qty |
|---------------------|--------------------|--|------------|
| | 20-7911-01-01 | Fitting, Oil Cooler/Oil Pump | 3 |
| | 956 640 | (Alternate to 20-7911-01-01) | opt. |
| | 20-7911-01-02 | Fitting, Crankcase Out Port | 1 |
| | 956 651 | (Alternate to 20-7911-01-02, 956 650) | opt. |
| | 20-7911-02-00 | Cover, Reworked, Oil Reservoir | 1 |
| | 956 508 | (Alternate to 20-7911-02-00, 956 438) | opt. |
| | 20-7911-01-03 | Placard, Cover, Oil Reservoir | 1 |
| | 9500-14MM | Washer, Sealing | 3 |
| | 230 385 | (Alternate to 9500-14MM) | opt. |
| | 9500-16MM | Washer, Sealing | 1 |
| | 430 622 | (Alternate to 9500-16MM) | opt. |
| | 156F062E0232D245 | Assy., Hose, Oil Reservoir to Oil Cooler | 1 |
| | AE7013H0232-245 | (Alternate to 156F062E0232D245) | opt. |
| | 156F115E0280D230 | Assy., Hose, Sump to Oil Reservoir | 1 |
| | AE7028H0280-230 | (Alternate to 156F115E0280D230) | opt. |
| | 156F062E0164D025 | Assy., Hose, Oil Cooler to Pump | 1 |
| | AE7013H0164-025 | (Alternate to 156F062E0164D025) | opt. |
| | MS3367-5-9 | Tie-down strap | 6 |
| | 850-490 | O-ring | 1 |

The material listed above is available as a kit by ordering P/N DA20-79-05AMK0

SERVICE BULLETIN



Service Bulletin No.: DA-CH-No Rev X

Date Issued: DD Month YYYY

Title: Title for the Service Bulletin

Page: 2 of 6

8. Special Tools: N/A

9. References: DA20-A1 Aircraft Maintenance Manual, Document Number DA201.
DA20-A1 Airplane Flight Manual, Document Number DA202.
Overhaul Manual for ROTAX 912 F Aircraft Engine, Edition:0 of 1996 06 01
Spare Parts List for ROTAX Engine Type 912 F, Edition: 09 1995
Maintenance Manual for ROTAX Engine Type 912 F, Edition: 0 of 1994 12 22

10. Accomplishment Instructions:

- 10.1 Remove upper and lower cowlings.
- 10.2 Remove and disassemble oil reservoir from aircraft in accordance with Rotax Maintenance Manual.
- 10.3 Assemble reservoir with supplied cover 20-7911-02-00 and O-ring 850-490 in reversed sequence of disassembly. Leave clamp loose to allow adjustment of orientation on installation.
- 10.4 Remove existing oil lines, i.e. sump to reservoir, reservoir to cooler, and cooler to pump, using a suitable container for oil.
- 10.5 Remove and discard the adapter fittings and sealing washers from oil cooler, engine sump and pump inlet.
- 10.6 Install remaining parts from kit as shown in Figure 1.
- 10.7 Torque adapters as follows:

| Adapter | Torque, N.m (in.lbs) |
|------------------------------|---------------------------|
| Crankcase out port (M16x1.5) | 35 (310) |
| Oil cooler (M14x1.5) | 22 (195) |
| Oil pump inlet (M14x1.5) | 22 (195) with Loctite 222 |

- 10.8 Route and secure oil lines as shown in Figures 2 and 3 using supplied tie-down straps, MS3367-5-9. ORIENT FITTINGS AND HOSES TO AVOID CONTACT WITH RADIATOR, ENGINE MOUNT AND CABIN HEATER SHROUD.
- 10.9 Ensure reservoir is in lowest position on engine mount. Do not allow reservoir to contact oil cooler shroud or upper surface of coolant overflow bottle.
- 10.10 Connect oil reservoir vent line.

SERVICE BULLETIN



Service Bulletin No.: DA20-79-05 Rev 3

Date Issued: January 19, 2009

Title: DA20 A1 - Oil Line Retrofit - F3 Engine

Page: 3 of 6

- 10.11** Install slotted head screw M10X1X8, (p/n 440 061 not supplied) using Loctite 222 in open port of reservoir cover in accordance with Spare Parts List.
- 10.12** Tighten reservoir clamp, all other fittings and adapters. Safety wire reservoir clamp such that the lever will not unlatch.
- 10.13** Fill reservoir with oil as specified in Rotax Maintenance Manual.
- 10.14** Run engine and ensure no leaks.
- 10.15** Install upper / lower cowl and ensure lines and / or reservoir do not contact cowl.
- 10.16** Return removed reservoir cover to Diamond Aircraft Industries for core credit.
- 10.17** Make the appropriate entry into the aircraft records.

SERVICE BULLETIN



Service Bulletin No.: DA-CH-No Rev X

Date Issued: DD Month YYYY

Title: Title for the Service Bulletin

Page: 4 of 6

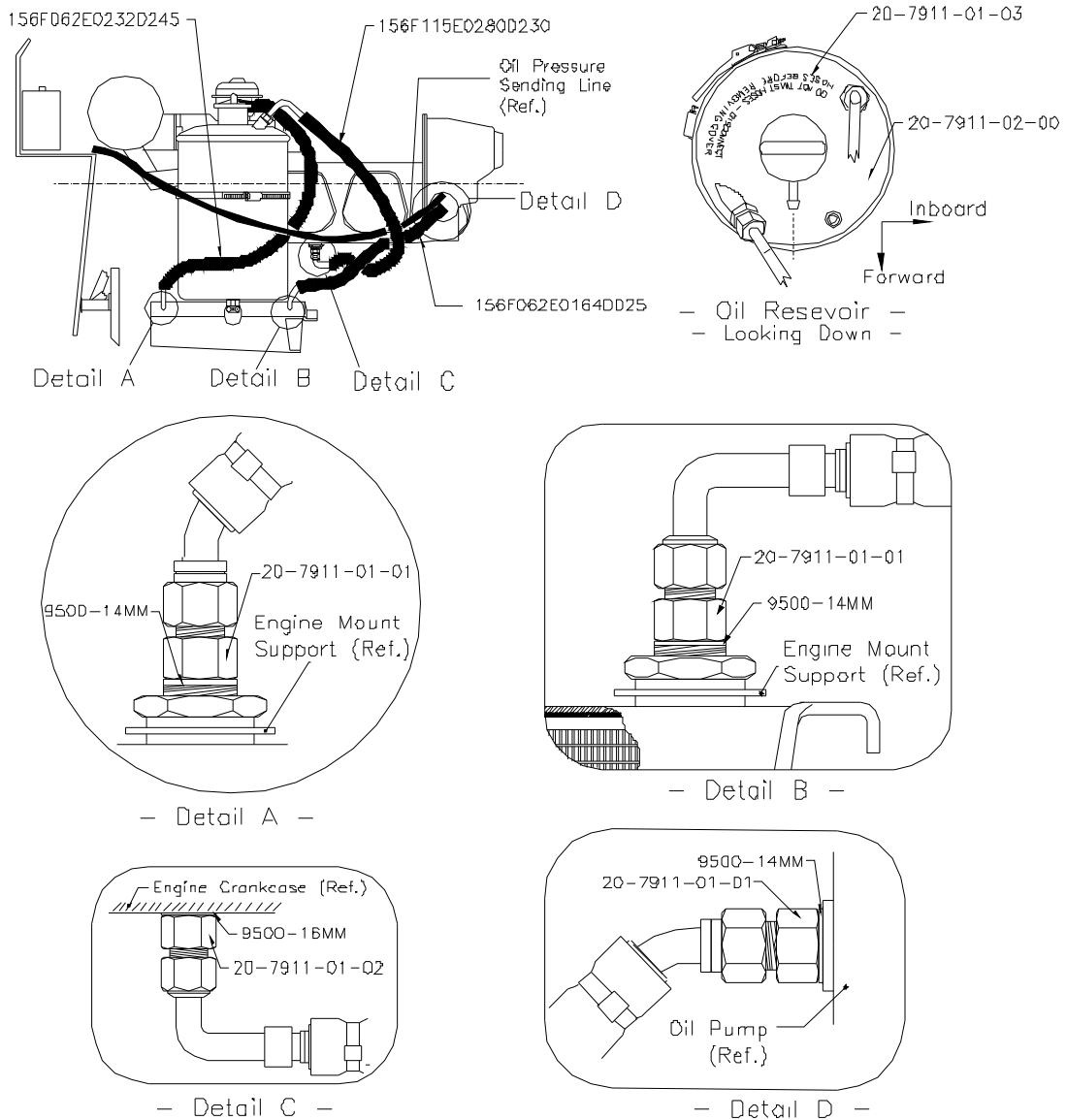

Figure 1

SERVICE BULLETIN



Service Bulletin No.: DA20-79-05 Rev 3

Date Issued: January 19, 2009

Title: DA20 A1 - Oil Line Retrofit - F3 Engine

Page: 5 of 6

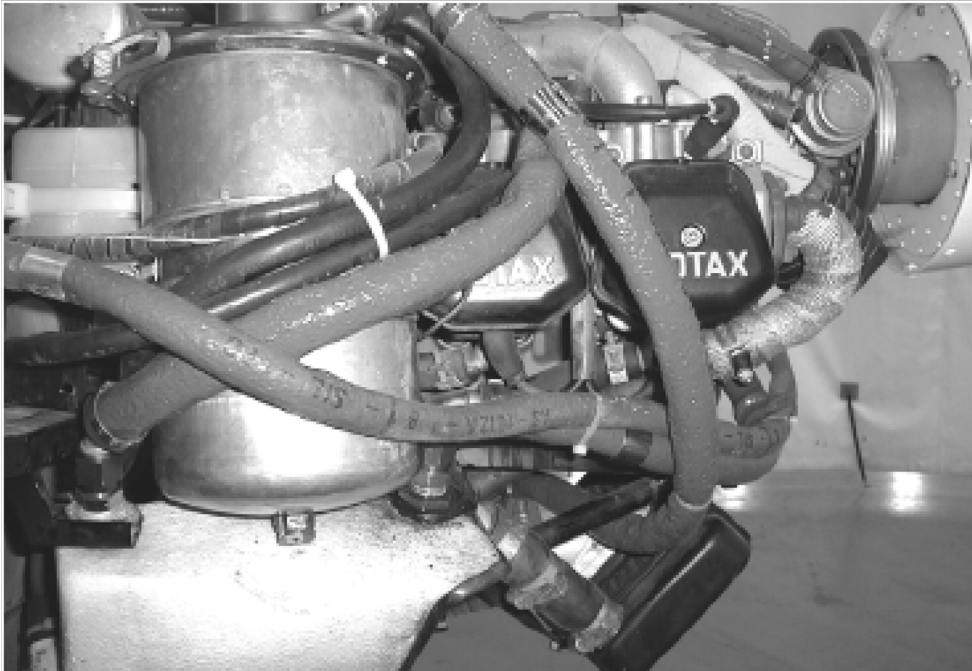

Figure 2 - Routing and securing oil lines (RH, looking inboard)

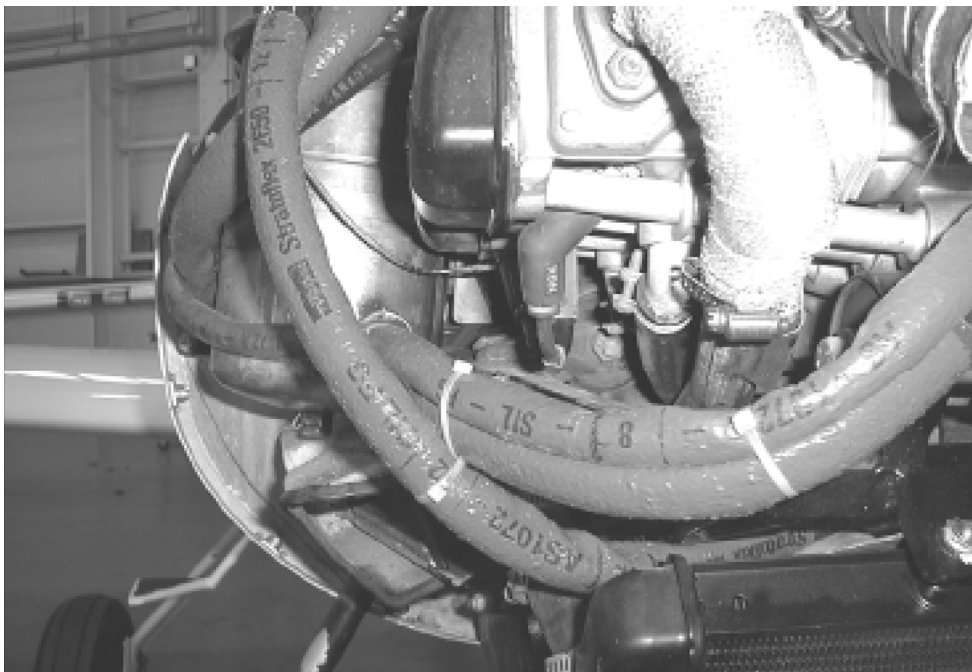

Figure 3 - Routing and securing oil lines (front, looking aft)

SERVICE BULLETIN



Service Bulletin No.: DA-CH-No Rev X

Date Issued: DD Month YYYY

Title: Title for the Service Bulletin

Page: 6 of 6

11. Weight and Balance: Weight and balance is not significantly affected by this Service Bulletin.

12. Availability: Contact Diamond Aircraft.

To obtain satisfactory results, procedures specified in this service bulletin must be accomplished in accordance with accepted methods and current government regulations. Diamond Aircraft Industries Inc. cannot be responsible for the quality of work performed in accomplishing the requirements of this service bulletin. Diamond Aircraft reserves the right to void continued warranty coverage in the area affected by this service bulletin if it is not incorporated.

If you no longer own the aircraft to which this service bulletin applies, please forward it to the current owner and send the name of the current owner to Diamond Aircraft Industries Inc. at the address below.

Diamond Aircraft Industries Inc. 1560 Crumlin Sideroad, London, Ontario, Canada N5V 1S2

Customer Support: Phone: (519) 457-4041 Fax: (519) 457-4045 E-mail: custsupp@diamondair.com

Technical Publications: Phone: (519) 457-4030 Ext. 3173 E-mail: techpubs@diamondair.com

COPYRIGHT 2008