

SERVICE BULLETIN



Service Bulletin No.: DA20-27-01, Rev. 0

Date Issued: March 9, 1996

Title: Flap Actuator

Page: 1 of 4

-
- 1. ATA Code:** 2750
 - 2. Effectivity:** All DA 20 Katana fitted with flap actuator assembly Part Number CARR 22x50x1/D12B (aircraft serial number 10002 to 10038).
 - 3. General:** This Bulletin describes replacement of the flap actuator motor (12 V) Part Number CARR 22x50x1/D12B with a 24 V motor Part Number CARR 22x50x1/D24B and current limiter. The replacement of the 12 V motor with the 24 V motor and current limiter reduces the force on the flaps during extension.
 - 4. Compliance:** Prior to or at next 200 hr inspection, but no later than May 1, 1996
 - 5. Approval:** Engineering data referenced or contained in this bulletin is Transport Canada approved.
 - 6. Labor:** Approximately 5 man hour will be required to accomplish this Service Bulletin.
 - 7. Material:**

<u>Description</u>	<u>P/N</u>
Machine Screw (Philips) (x4)	MS35206-216
Washer (x8)	AN960C4L
Self-locking nut (x4)	MS21083B04
Current Limiter Assembly	20-2750-11-00
24 V Motor	CARR22x50x1/D24B
Parts Kit-gasket, roll pin, cap screws, and washers	MMK22
 - 8. Kit Price:**

Above material may be ordered as kit DA20-27-01MK

The kit detailed in this service bulletin is available from Diamond Aircraft Industries with the terms and conditions described below. Kits may be obtained by submitting a purchase order, specifying serial number of aircraft to Diamond Aircraft Customer Support department, Warranty Administration
Fax: 519-457 4045.

Kits ordered prior to 60 days from issue date of this service bulletin are available at no-charge. Kits ordered after 60 days are subject to charge.
 - 9. Special Tools:** 4 mm Allen key
3/32 drift punch
1/8 drift punch
soft jawed vice
inclinometer
 - 10. References:** Work Instructions - SKF Linear Actuators (attached)
DA 20 Katana Maintenance Manual

11. Accomplishment Instructions

- 11.1 Remove pilot seat in accordance with Chapter 25-10 of the Maintenance Manual.
- 11.2 Unload flaps by lowering to T/O position.
- 11.3 Remove bolt AN4-16A which secures front end of actuator.
- 11.4 Remove existing 12 V motor, insert worm screw into 24 V motor, and reinstall 24 V motor in accordance with the manufacturers' instructions (attached).
- 11.5 Re-install AN4-16A bolt to secure actuator.
- 11.6 Drill 0.125" diameter holes for the current limiter in the forward control bulkhead, locating them in accordance with Figure 1.
- 11.7 Secure current limiter with hardware supplied as per Figure 1.
- 11.8 Connect motor wires and current limiter wires in accordance with Figure 2 and fasten loose wires with tie-wraps.
- 11.9 Strike out existing Part Number CARR 22x50x1/D12B, located on Actuator Gear Box, using permanent ink and re-identify Actuator assembly as Part Number CARR 22x50x1/D24B, using permanent ink. New Part Number may be located on any accessible surface of Actuator assembly.
- 11.10 Rig Flaps
 - 11.10.1 Loosen nut on flap up-stop to provide 1/4" of free play.
 - 11.10.2 Place flaps in fully retracted position using tape.
 - 11.10.3 Adjust flap long rods to engage rod ends in flap bellcrank and install bolts.
 - 11.10.4 Remove tape from flaps.
 - 11.10.5 If flaps slacken at all, return flaps to cruise position by adjusting flap short rods.
 - 11.10.6 Set flap pre-load (3-5 kg/6.6-11 lbs upward at flap trailing edge) using a spring scale or weights.
 - 11.10.7 Level aircraft. Place inclinometer on underside of flap on outboard side of flap bellcrank.
 - 11.10.8 Note angle of flaps in cruise, take off and landing positions.
 - 11.10.9 Adjust flap short rods to bring flaps within limits, refer to Maintenance Manual Sub-Chapter 06-00.

CAUTION: Extending short rods increases the pre-load on flaps in cruise position. After making adjustments, flaps should be retracted gradually to ensure that pre-load values are not exceeded.

 - 11.10.10 Retract flaps to cruise position and check flap pre-load.
 - 11.10.11 If pre-load is above limits, loosen gear clamps on flap limit switch tray and move tray slightly forward. If preload is below limits move tray slightly aft, refer to Fig. 3.
 - 11.10.12 Recheck flap readings.
 - 11.10.13 If any readings are out of limits, adjustments can be made by moving the appropriate individual limit switch (Figure 3).
- 11.11 Cycle flaps and check current limiter voltage in accordance with Maintenance Manual Sub-Chapter 27-50.
- 11.12 With flaps in cruise (UP) position, readjust flap up-stop so that washers can still be rotated by hand.

12. Weight and Balance: N/A

Service Bulletin No.: DA20-27-01, Rev. 0

Date Issued: March 9, 1996

Title: Flap Actuator

Page: 3 of 4

13. Electrical Load Data: N/A

14. Credit: A full parts credit and labour allowance of 5 hours will be issued upon receipt of a completed warranty application form and the obsolete 12 V motor assembly.

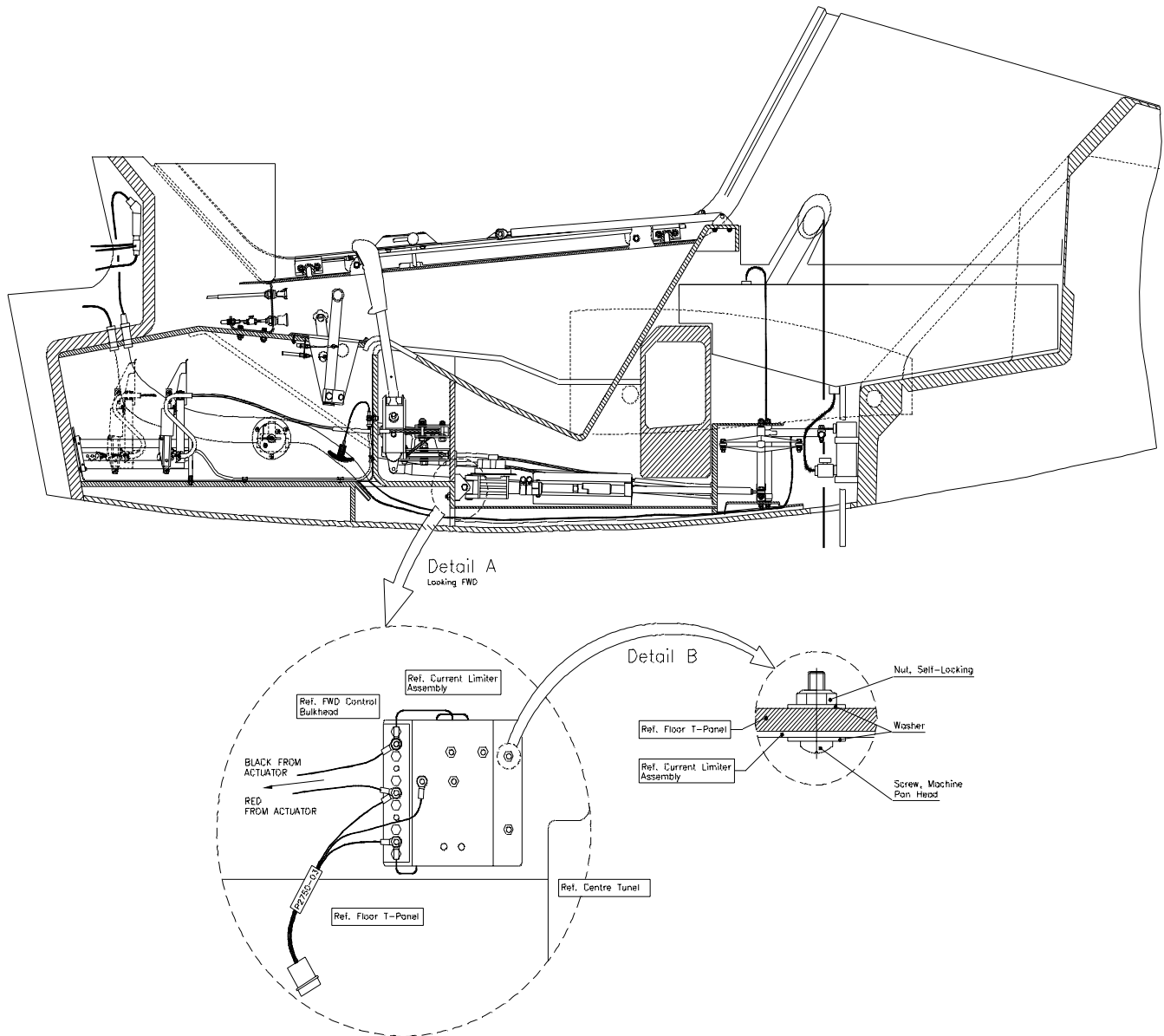

Figure 1. Current Limiter Mounting

Figure 2. Wiring Diagram - Flap Actuator, Motor and Current Limiter

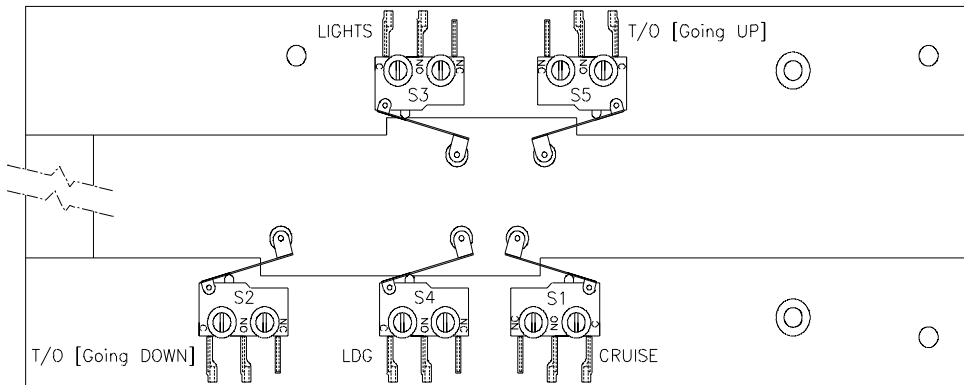
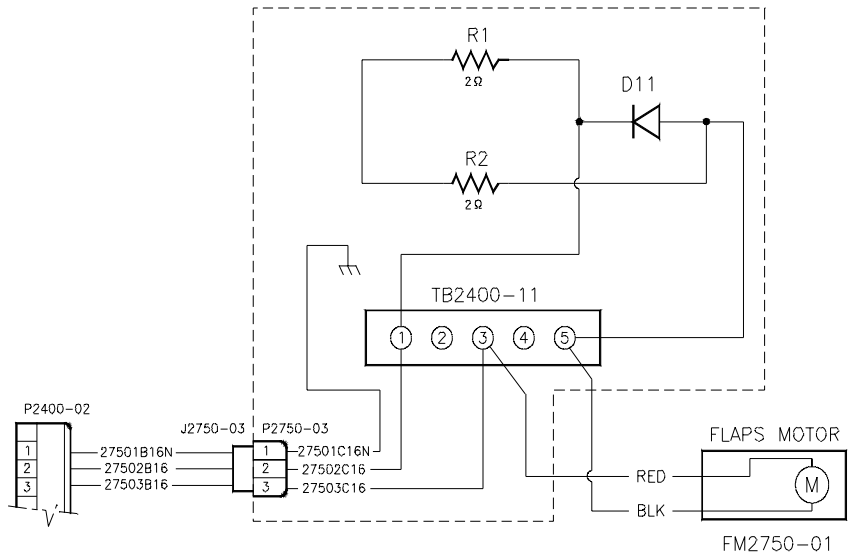

Figure 3. Flap Limit Switch Tray

To obtain satisfactory results, procedures specified in this service information letter must be accomplished in accordance with accepted methods and current government regulations. Diamond Aircraft Industries Inc. cannot be responsible for the quality of work performed in accomplishing the requirements of this service information letter.

Diamond Aircraft Industries Inc. 690 Crumlin Sideroad, London, Ontario, Canada N5V 1S2
 Phone: (519) 457-4000 Fax: (519) 457-4037