

SERVICE BULLETIN



Service Bulletin No.: DAC1-11-01 Rev 1

Date Issued: 21 March 2011

Title: Chinese Placards and Markings

Page: 1 of 8

1. **ATA Code:** 1120, 1130
2. **Effectivity:** All DA20-C1 Aircraft for operation under Chinese registry.
3. **General:** This Service Bulletin introduces the Chinese Placards and Markings and describes modifications required for aircraft operating under Chinese registry. Revision 1 of this Service Bulletin changes the compliance.
4. **Compliance:** For newly manufactured aircraft, prior to operation of the aircraft in China under Chinese registry; or within the next 100 hours of operation for aircraft already exported to China.
5. **Approval:** Engineering data referenced or contained in this Service Bulletin is approved as part of the type design.
6. **Labour:** Approximately 1 hour will be required to accomplish this Service Bulletin.

This estimate is for direct labour performed by a technician and it does not include setup, planning, familiarization, cure time, part fabrication or tool acquisition.

7. Material:	Part Number	Description	Qty
	22-3910-04-09X01	Placard, Chinese, VLA Limits	1
	22-1120-05-01	Placard Canopy Lock Postion Exterior, Chinese	1
	22-1120-05-19	Placard Canopy Latching Exterior LH, Chinese, Illuminated	1
	22-1120-05-20	Placard Canopy Latching Exterior RH, Chinese, Illuminated	1
	22-1130-05-05	Placard Rescue Hammer, Chinese, Illuminated	1
	22-1130-05-12	Placard Baggage, Chinese	1
	22-1130-05-20	Placard Fuel Pull Off, Chinese, Illuminated	1
	22-1130-05-31	Placard Canopy Latching Interior LH, Chinese, Illuminated	1
	22-1130-05-32	Placard Canopy Latching Interior RH, Chinese, Illuminated	1

The above material may be ordered as kit DAC1-11-01-AMK0.

SERVICE BULLETIN



Service Bulletin No.: DAC1-11-01 Rev 1

Date Issued: 21 March 2011

Title: Chinese Placards and Markings

Page: 2 of 8

8. Special Tools: No special tools are required.

9. References: DA20-C1 Aircraft Maintenance Manual, Document Number DA201-C1.
DA20-C1 Illustrated Parts Catalogue, Document Number DA203-C1.

10. Accomplishment Instructions:

WARNING: DO NOT GET SOLVENT ON YOUR SKIN. DO NOT BREATH SOLVENT VAPOR.
SOLVENT CAN CAUSE DISEASE OR ILLNESS.

10.1 Replace the English language placards with the Chinese language placards as shown in Figures 1 and 2.

10.2 Replace the canopy lock position placard (P/N 22-1120-05-01).

10.2.1 Use a hot air blower and plastic spatula to carefully loosen the canopy lock placard from the fuselage skin, then remove the placard.

10.2.2 Remove the remaining sealant from the placard base and the aircraft skin in the mounting area. Be careful to not damage the aircraft skin.

10.2.3 Clean the surface where the new placard will go with a commercial solvent.

10.2.4 Remove the protective backing, then align and install the new placard.

10.2.5 Apply an aerodynamic seal around the placard.

10.3 Replace the exterior canopy latching placards (P/Ns 22-1120-05-19 and 22-1120-05-20)

10.3.1 Remove the canopy latching handle.

NOTE: Refer to the Aircraft Maintenance Manual DA201-C1 (52-10) for the instructions to remove and install the canopy latching handle.

10.3.2 Use a hot air blower and plastic spatula to carefully loosen the canopy latching placard from the fuselage skin, then remove the placard.

10.3.3 Remove the remaining sealant from the placard base and the aircraft skin in the mounting area. Be careful to not damage the aircraft skin.

10.3.4 Clean the surface where the new placard will go with a commercial solvent.

10.3.5 Remove the protective backing, then align and install the new placard.

- 10.3.6 Apply an aerodynamic seal around the placard.
- 10.3.7 Install the canopy latching handle.
- 10.4 Replace the interior canopy latching placards (P/Ns 22-1120-05-31 and 22-1120-05-32)
 - 10.4.1 Remove the four screws holding the placard to the aircraft.
 - 10.4.2 Use a hot air blower and plastic spatula to carefully loosen the placard, then remove the placard.
 - 10.4.3 Clean the surface where the new placard will go with a commercial solvent.
 - 10.4.4 Remove the protective backing, then align and install the new placard.
 - 10.4.5 Install the four screws.
- 10.5 Replace the plastic foil placards.
 - 10.5.1 Refer to Figures 1 and 2 to identify the plastic foil placards and the location of each placard.
 - 10.5.2 Remove the old placard.
 - Heat the placard with a hot air blower
 - Lift one corner of the placard
 - Pull the placard off.
 - 10.5.3 Clean the surface where the new placard will go with a commercial solvent.
 - 10.5.4 Remove the protective backing from the new placard.
 - 10.5.5 Install the new placard in the correct position.
- 10.6 Make a log book entry that this Service Bulletin has been incorporated.

SERVICE BULLETIN



Service Bulletin No.: DAC1-11-01 Rev 1

Date Issued: 21 March 2011

Title: Chinese Placards and Markings

Page: 4 of 8

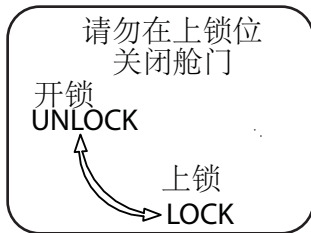

P/N 22-1120-05-01
Placard-Canopy Lock Position Exterior



P/N 22-1130-05-05
Placard, Rescue Hammer

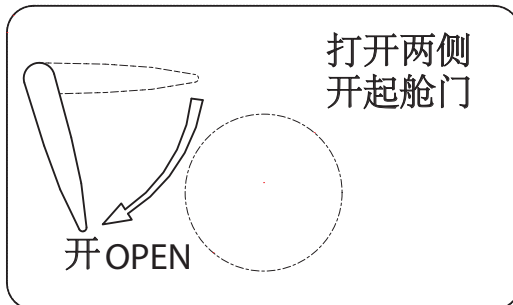

P/N 22-1120-05-19
Placard-Canopy Latching Exterior LH

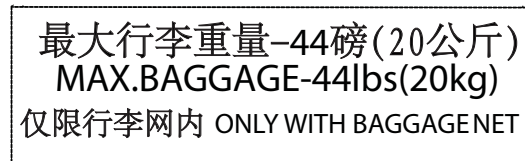

P/N 22-1130-05-12
Placard, Baggage

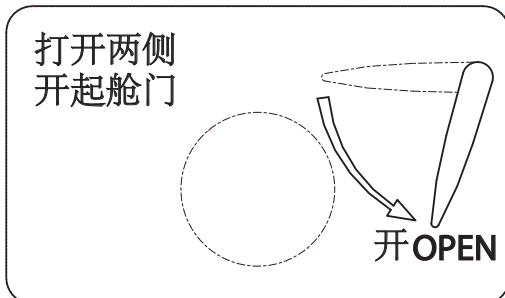

P/N 22-1120-05-20
Placard Canopy Latching Exterior RH



P/N 22-1130-05-20
Placard, Fuel Pull Off

Figure 1 (Sheet 1) - Aircraft Placards

SERVICE BULLETIN



Service Bulletin No.: DAC1-11-01 Rev 1

Date Issued: 21 March 2011

Title: Chinese Placards and Markings

Page: 5 of 8

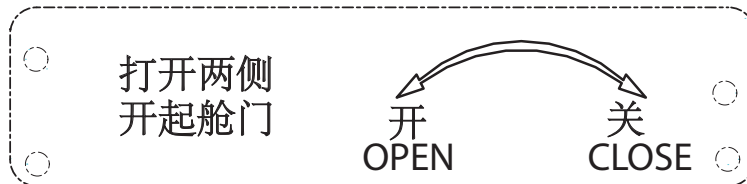

P/N 22-1130-05-31
Placard-Canopy Latching Interior LH

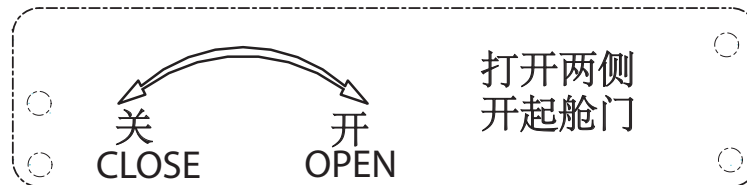

P/N 22-1130-05-32
Placard-Canopy Latching Interior RH

这架飞机被列为超轻型飞机，仅批准在非结冰条件下目视飞行。禁止所有的特技飞行动作，包括有意旋转。有关其他限制，请查看飞行手册。

P/N 22-3910-04-09x01
Label, VLA Limits Placard, Chinese

Figure 1 (Sheet 2) - Aircraft Placards

SERVICE BULLETIN



Service Bulletin No.: DAC1-11-01 Rev 1

Date Issued: 21 March 2011

Title: Chinese Placards and Markings

Page: 6 of 8

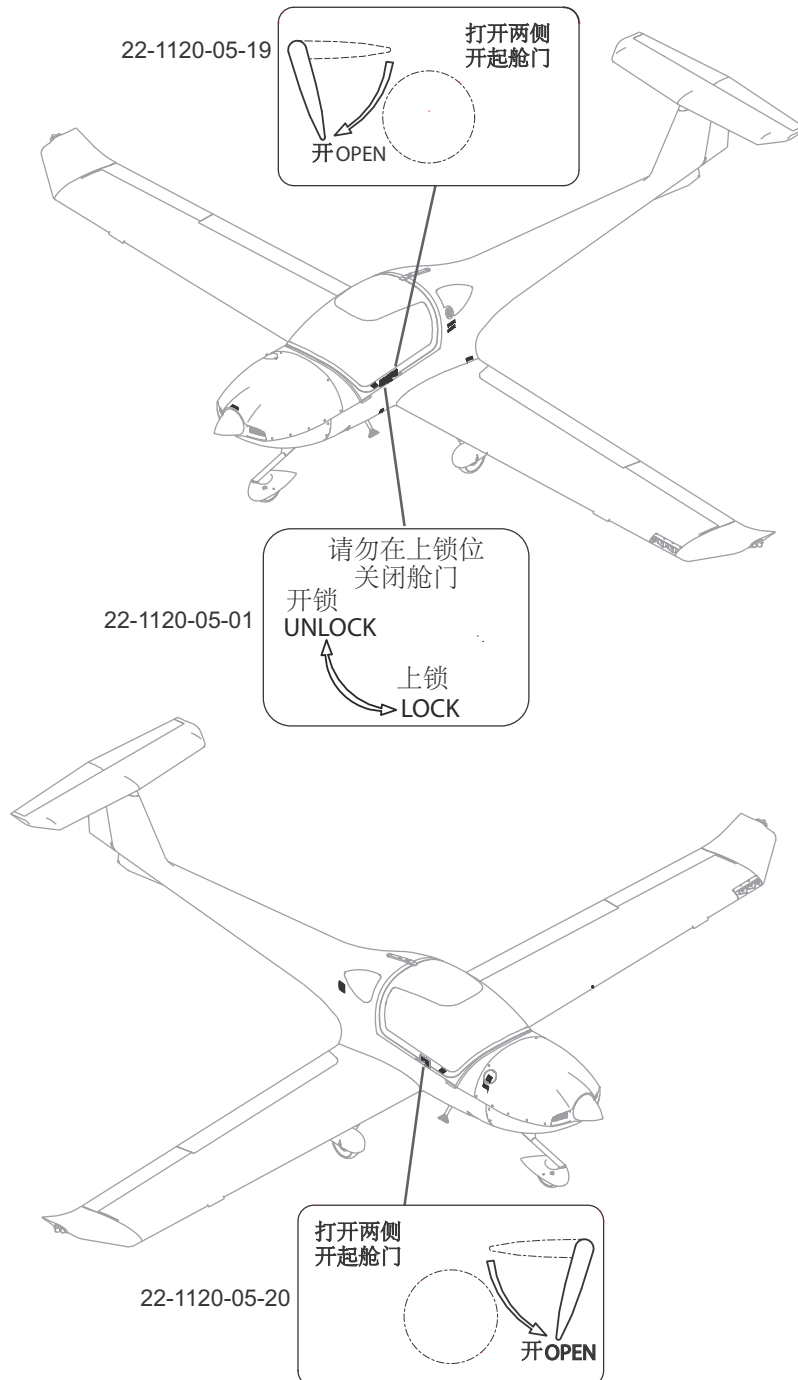

Figure 2 (Sheet 1) - Aircraft Placards - Locations

SERVICE BULLETIN



Service Bulletin No.: DAC1-11-01 Rev 1

Date Issued: 21 March 2011

Title: Chinese Placards and Markings

Page: 7 of 8

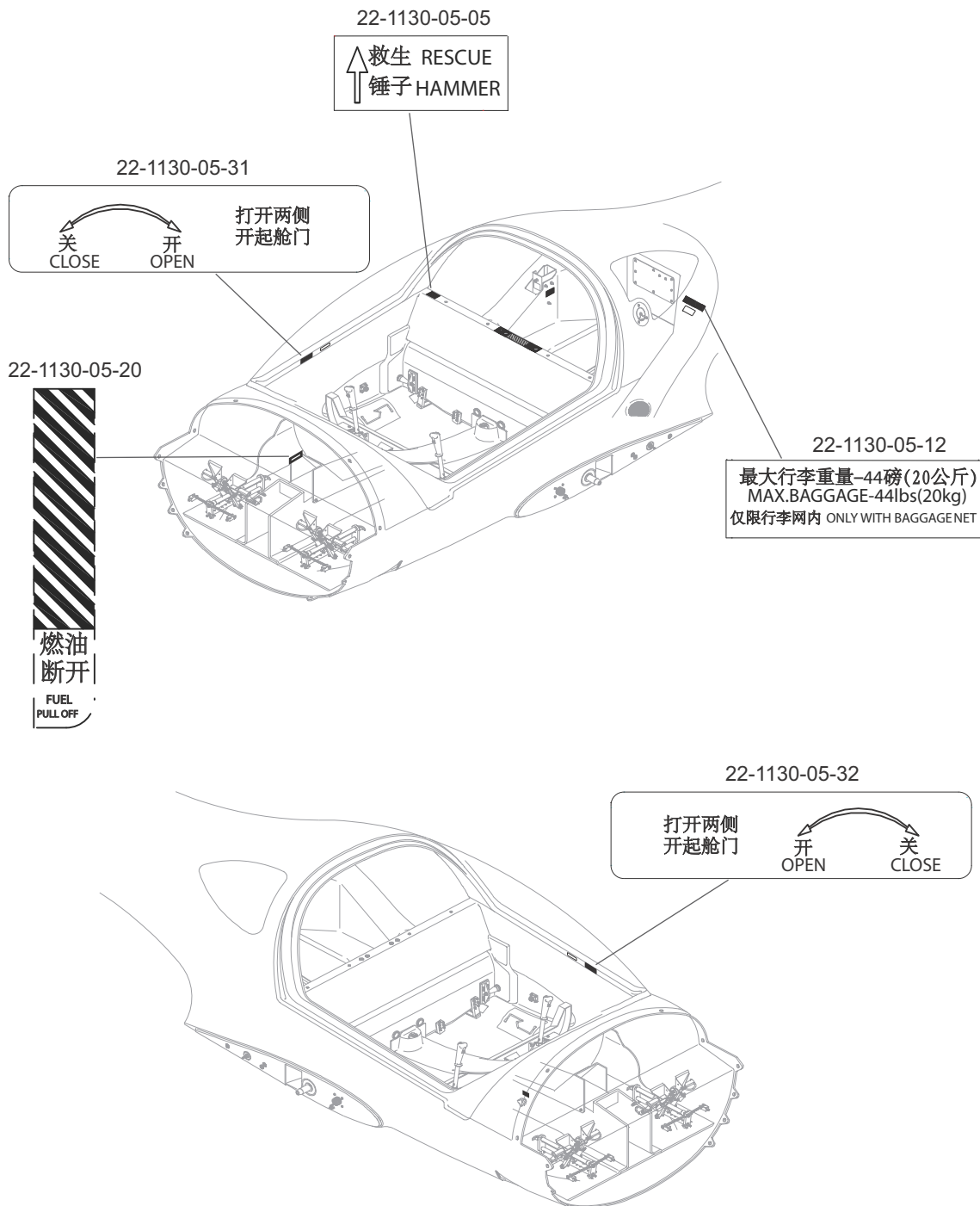

Figure 2 (Sheet 2) - Aircraft Placards - Locations

SERVICE BULLETIN



Service Bulletin No.: DAC1-11-01 Rev 1

Date Issued: 21 March 2011

Title: Chinese Placards and Markings

Page: 8 of 8

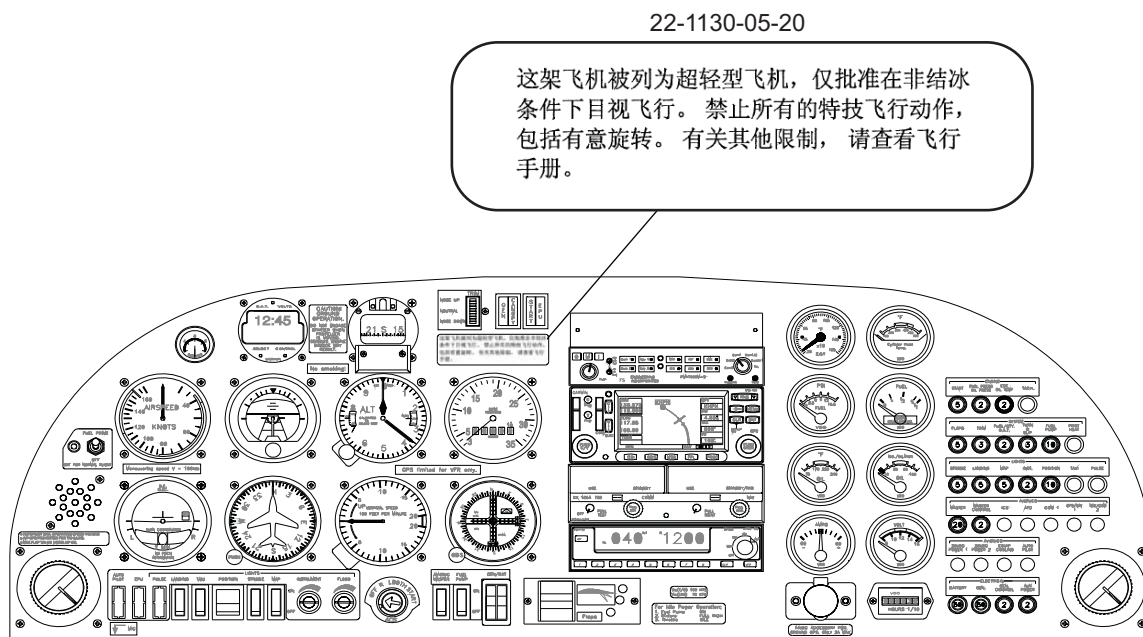

Figure 2 (Sheet 3) - Aircraft Placards - Locations

- 11. **Weight and Balance:** There is no impact to the weight and balance.
- 12. **Availability:** Contact Diamond Aircraft.
- 13. **Electrical Load Data:** There is no impact to the electrical load.
- 14. **Credit:** None.

To obtain satisfactory results, procedures specified in this service bulletin must be accomplished in accordance with accepted methods and current government regulations. Diamond Aircraft Industries Inc. cannot be responsible for the quality of work performed in accomplishing the requirements of this service bulletin. Diamond Aircraft reserves the right to void continued warranty coverage in the area affected by this service bulletin if it is not incorporated. If you no longer own the aircraft to which this service bulletin applies, please forward it to the current owner and send the name of the current owner to Diamond Aircraft Industries Inc. at the address below.

Diamond Aircraft Industries Inc. 1560 Crumlin Sideroad, London, Ontario, Canada N5V 1S2

Customer Support: Phone: (519) 457-4041 Fax: (519) 457-4045 E-mail: custsupp@diamondair.com
Technical Publications: Phone: (519) 457-4030 Ext. 3173 E-mail: techpubs@diamondair.com