

SERVICE BULLETIN



Service Bulletin No.: DA20-32-06 Rev 0

Date Issued: 15 July 2011

Title: NLG Wheel and Fork Installation Improvements

Page: 1 of 5

-
- 1. ATA Code:** 3220
- 2. Effectivity:** All DA20-A1 aircraft.
- 3. General:** This service bulletin provides information regarding updated NLG gear fork and wheel assembly installations to reduce wear and maintain steering friction. It has been noted during service that there has been issues with frequent adjustment of the steering friction and nose wheel shimmy. Incorporation of this service bulletin will assist with these issues.
- 4. Compliance:** This service bulletin is highly Recommended and should be completed at the next 200 hour or annual inspection
- 5. Approval:** Engineering data referenced or contained in this service bulletin is approved as part of the type design.
- 6. Labour:** Approximate time required to complete the Service Bulletin - 1 hour.

This estimate is for direct labour performed by a technician and it does not include setup, planning, familiarization, cure time, part fabrication or tool acquisition.

7. Material:

Part Number	Description	Qty
<i>New Parts</i>		
681-271	Belleville Spring	2
AN960-616L	Flat Washer - Steel	1
22-3220-00-25	0.010" Shim	2
22-3220-00-26	0.020" Shim	2
<i>Original Parts (use if necessary to replace damaged or worn parts)</i>		
20-3220-00-20	Thrust Washer	1
20-3220-00-23	Stop Plate	1
20-3220-00-17	Spacer	1
AN960-616	Washer	2
AN310-6	Castellated Nut	1
MS24665-285	Cotter Pin	1
CRC SP-400	Corrosion Inhibitor	AR

8. Special Tools: N/A

9. References: DA20-A1 Aircraft Maintenance Manual, Document Number DA201.

SERVICE BULLETIN



Service Bulletin No.: DA20-32-06 Rev 0

Date Issued: 15 July 2011

Title: NLG Wheel and Fork Installation
Improvement

Page: 2 of 5

10. Accomplishment Instructions:

- 10.1 Either jack the aircraft in accordance with DA20-A1 AMM Chapter 07-10-00.
- 10.2 Remove the wheel in accordance with AMM Chapter 32-40-00
- 10.3 Remove NLG fork (A new fork assembly is available see SIL20A1-008) .
- 10.4 Inspect all parts for condition checking for cracks, corrosion and wear. New hardware should be used where necessary (For the fork assembly please review SIL20A1-008).
- 10.5 Apply CRC Corrosion Shell to the stud. Do not contaminate the tire or fiberglass.
- 10.6 Lubricate the axle in accordance with AMM Chapter 12-20-00.
- 10.7 Re install the fork using the new Belleville springs with the rest of the parts listed in figure 1. Be sure that both springs are installed with the open side facing up as per figure 1.

Note: The AN960-616L steel washer should be used if it is not possible to install the cotter pin correctly when adjusting the friction force.
- 10.8 Re install the wheel and use the shims to eliminate the gap between the axle spacer (20-3220-00-19) and the fork. Use a maximum of two shims and divide the shim installation evenly from side to side. Maximum difference between sides is 0.010". See figure 2.
- 10.9 Carry out friction adjustment as per AMM Chapter 32-20-00. Use the AN960-616L washer as noted above if required to properly install the fork and obtain the proper friction.
- 10.10 Make a log book entry that this Service Bulletin has been incorporated.

SERVICE BULLETIN



Service Bulletin No.: DA20-32-06 Rev 0

Date Issued: 15 July 2011

Title: NLG Wheel and Fork Installation Improvements

Page: 3 of 5

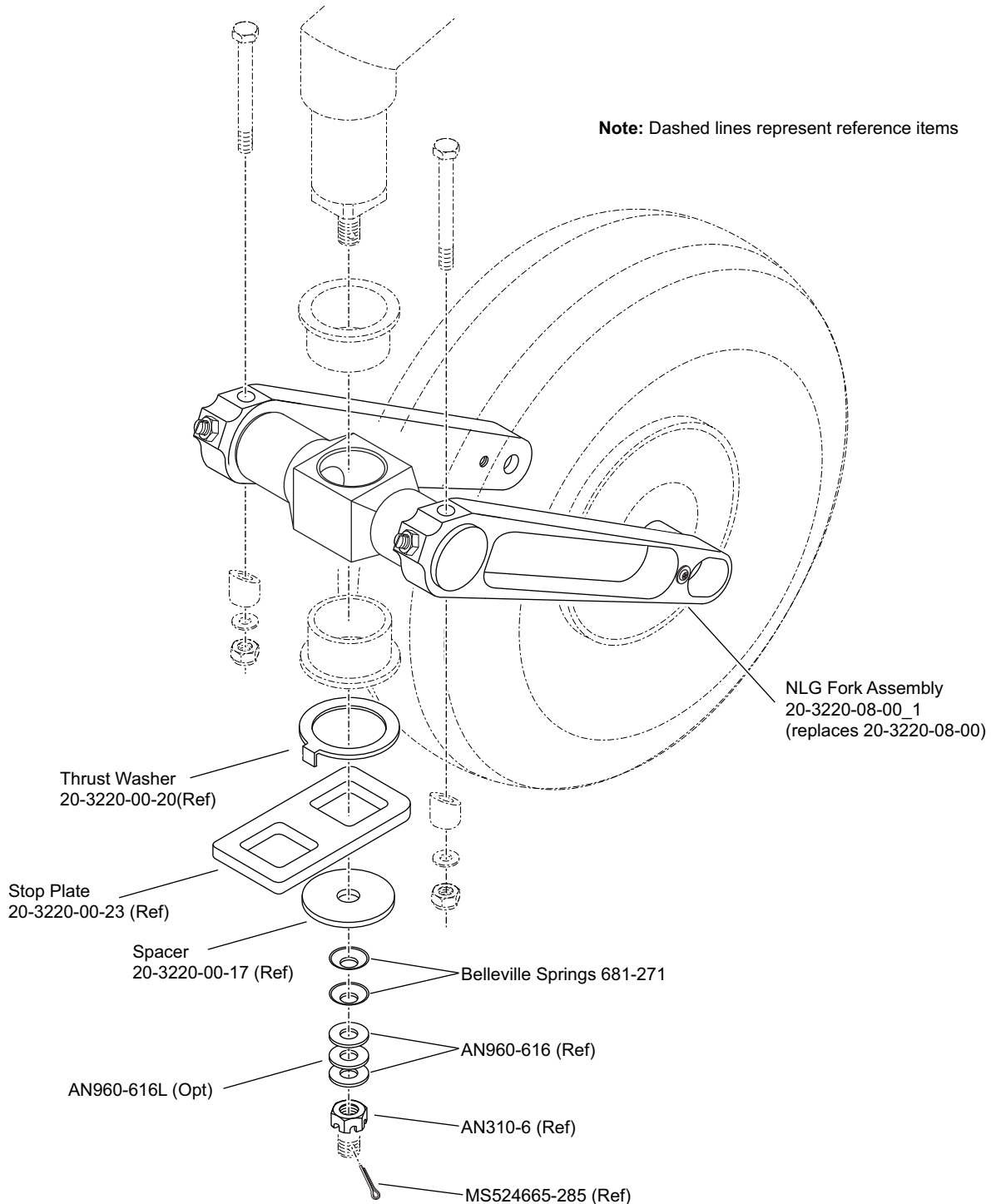

Figure 1 - NLG Fork Assembly Installation

SERVICE BULLETIN



Service Bulletin No.: DA20-32-06 Rev 0

Date Issued: 15 July 2011

Title: NLG Wheel and Fork Installation
Improvement

Page: 4 of 5

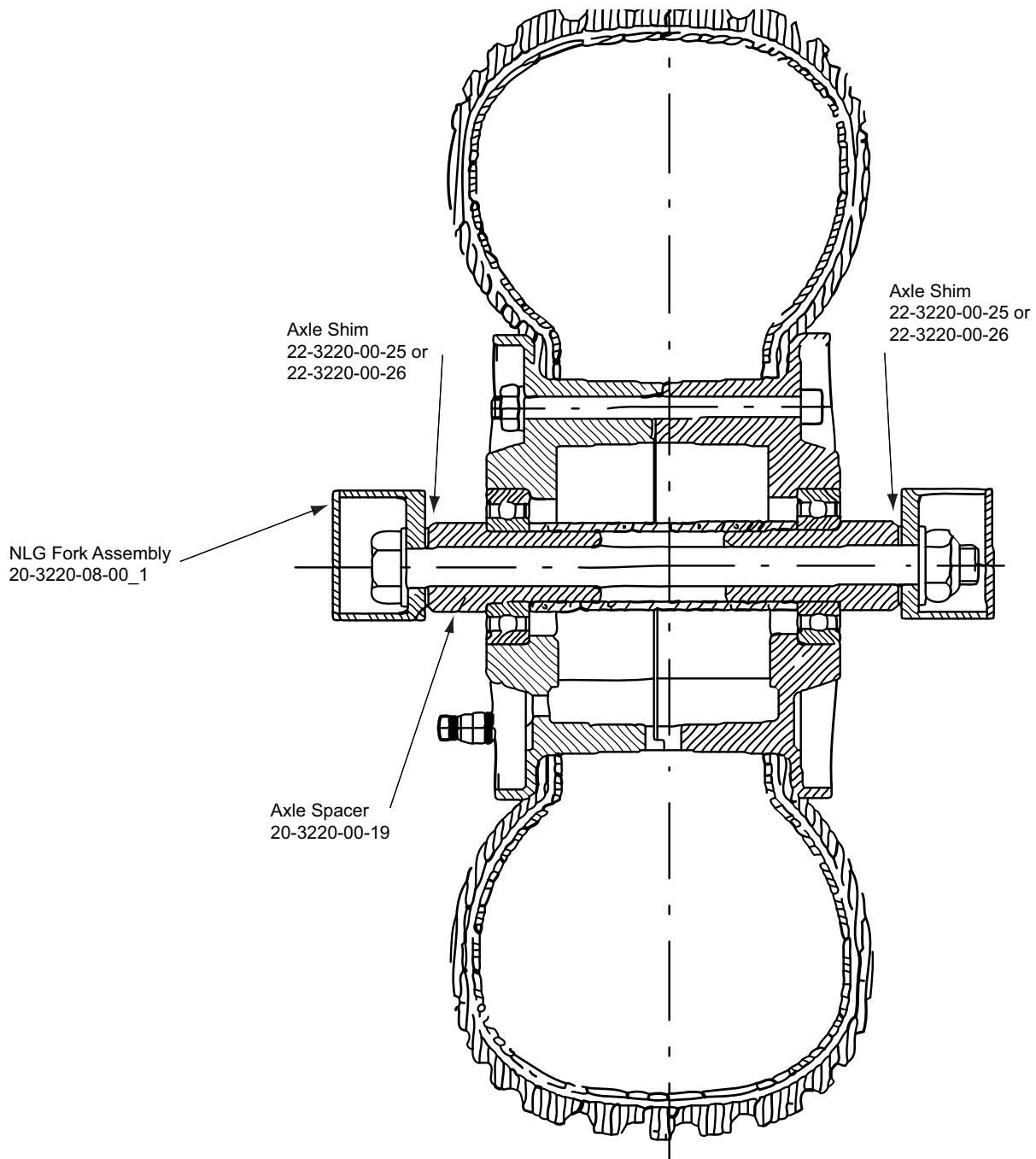

Figure 2 - NLG Wheel Installation with Shims

SERVICE BULLETIN



Service Bulletin No.: DA20-32-06 Rev 0

Date Issued: 15 July 2011

Title: NLG Wheel and Fork Installation
Improvements

Page: 5 of 5

-
- 11. Weight and Balance:** Weight and Balance is not affected by the installation of this Service Bulletin
- 12. Availability:** Contact Diamond Aircraft.

To obtain satisfactory results, procedures specified in this service bulletin must be accomplished in accordance with accepted methods and current government regulations. Diamond Aircraft Industries Inc. cannot be responsible for the quality of work performed in accomplishing the requirements of this service bulletin. Diamond Aircraft reserves the right to void continued warranty coverage in the area affected by this service bulletin if it is not incorporated.

If you no longer own the aircraft to which this service bulletin applies, please forward it to the current owner and send the name of the current owner to Diamond Aircraft Industries Inc. at the address below.

Diamond Aircraft Industries Inc. 1560 Crumlin Sideroad, London, Ontario, Canada N5V 1S2

Customer Support: Phone: (519) 457-4041 Fax: (519) 457-4045 E-mail: custsupp@diamondair.com
Technical Publications: Phone: (519) 457-4030 Ext. 3173 E-mail: techpubs@diamondair.com

COPYRIGHT 2011