

SERVICE BULLETIN



Service Bulletin No.: DA20-32-02 Rev 0

Date Issued: 8 January, 1999

Title: Nose Gear Fork, Fatigue

Page: 1 of 6

1. **ATA Code:** 3220
2. **Effectivity:** DA20-A1 aircraft.
3. **General:**

As a result of hard landings, cracks have appeared in the nose landing gear fork of some aircraft. This service bulletin is divided into two parts. Part 1 addresses an inspection of the Nose Gear Fork. Part 2 addresses modifications required to remove the Nose Gear Fork and replace it with an optional heavy duty fork.

Note: Diamond Aircraft recommends an upgrade of the Steering Stop Plate to P/N 20-3220-00-23 (ITEM 30 in Figure 1) in place of P/N 20-3220-00-18 (see Figure 3) installed on some aircraft, before accomplishment of Part 2 of this service bulletin.
4. **Compliance:**

Compliance with Part 1 of this service bulletin is urgently recommended upon receipt of this service bulletin.
Compliance with Part 2 is recommended.
5. **Approval:**

Engineering data referenced or contained in this service bulletin is approved as part of the type design.
6. **Labour:**

Approximately 0.5 hours will be required to accomplish Part 1 of this service bulletin. Approximately 2.0 hours will be required to accomplish Part 2 of this service bulletin.

This estimate is for direct labor performed by a technician and it does not include setup, planning, familiarization, cure time, part fabrication or tool acquisition.
7. **Material:**

Part Number	Description	Qty
20-3220-08-00	Fork Assembly, Nose Landing Gear	1
MS24665-285	Pin, Cotter	1
20-3220-00-23	Stop Plate, Steering	1

Materials required but not supplied: procure locally.

Aeroshell Grease 22	Grease	A/R
Mastinox 6856 K	Corrosion Inhibitor	A/R
or		
LPS-3	Corrosion Inhibitor	A/R
Loctite 242	Thread Locker	A/R
8. **Special Tools:** N/A
9. **References:** DA20 Maintenance Manual, Document # DA201.

10. Accomplishment Instructions:

Part 1

- 10.1.1** Remove the wheel fairing if one is installed:
- Remove 6 Allen screws attaching the left half of the fairing to the right half.
 - Remove the LH and RH mounting screws.
- 10.1.2** Clean the Nose Gear Fork.
- 10.1.3** Visually inspect left and right hand forks, one to two inches from the axle center, for cracks. Refer to Figure 2 for exact location.
- 10.1.4** Continued inspection every 100 hours in accordance with the Aircraft Maintenance Manual is required. Refer to document # DA201, Chapter 05-20, Landing Gear Inspection.

Part 2

- 10.2.1** Raise the Nose Wheel off the ground using weights and a strap around the rear fuselage.
- 10.2.2** Put a padded trestle under the front fuselage just aft of the nose gear mounting.
- 10.2.3** Remove the wheel fairing if one is installed:
- Remove 6 Allen screws attaching the left half of the fairing to the right half.
 - Remove the LH and RH mounting screws.
- 10.2.4** Remove the wheel from the fork:
- Remove the 7/16" nut from the axle bolt.
 - Remove the axle bolt.
- 10.2.5** Remove fork assembly from strut:
- Remove cotter pin from pivot nut.
 - Remove 9/16" pivot nut.
 - Slide fork assembly down and off strut.
- 10.2.6** Clean all mating surfaces
- 10.2.7** Apply Aeroshell grease 22 to strut axle and pack fork pivot bore. Remove excess grease after pivot nut is torqued.
- 10.2.8** Install new fork assembly – refer to Figure 1 for assembly order.
- 10.2.9** Tighten pivot nut until a Breakout Force of 30 – 50 N (6.75 – 11.25 lbs.) is achieved in both directions along the axis of the axle (Figure 4).
- 10.2.10** Install new cotter pin. If cotter pin hole does not align, tighten the pivot nut to the next slot.

SERVICE BULLETIN



Service Bulletin No.: DA20-32-02 Rev 0

Date Issued: 8 January, 1999

Title: Nose Gear Fork, Fatigue

Page: 3 of 6

- 10.2.11 Apply CRC corrosion shell to pivot nut, washers and stud only. DO NOT contaminate fiberglass or tire.
- 10.2.12 Apply Mastinox 6856 K corrosion inhibitor or LPS-3 on shank of axle bolt. Clean Corrosion inhibitor from threads.
- 10.2.13 Install wheel with axle bolt and nut. Torque nut to 37.6 Nm (27.8 ft. lbs.).
- 10.2.14 Spin nose wheel. Make sure tube valve cap does not touch fork. Minimum clearance is 2 mm (0.08 in.).
- 10.2.15 Remove trestle and weights from fuselage. Lower nose to ground.
- 10.2.16 Install wheel fairing if equipped. Apply Loctite 242 to screw threads.

11. Weight and Balance:

The weight and balance is not affected by this Service Bulletin.

12. Availability:

Contact Diamond Aircraft.

To obtain satisfactory results, procedures specified in this service bulletin must be accomplished in accordance with accepted methods and current government regulations. Diamond Aircraft Industries Inc. cannot be responsible for the quality of work performed in accomplishing the requirements of this service bulletin. Diamond Aircraft reserves the right to void continued warranty coverage in the area affected by this Service Bulletin if it is not incorporated.

If you no longer own the aircraft to which this service bulletin applies, please forward it to the current owner and send the name of the current owner to Diamond Aircraft Industries, Inc., at the address below

Diamond Aircraft Industries Inc. 1560 Crumlin Sideroad, London, Ontario, Canada N5V 1S2
Phone: (519) 457-4041 Fax: (519) 457-4045

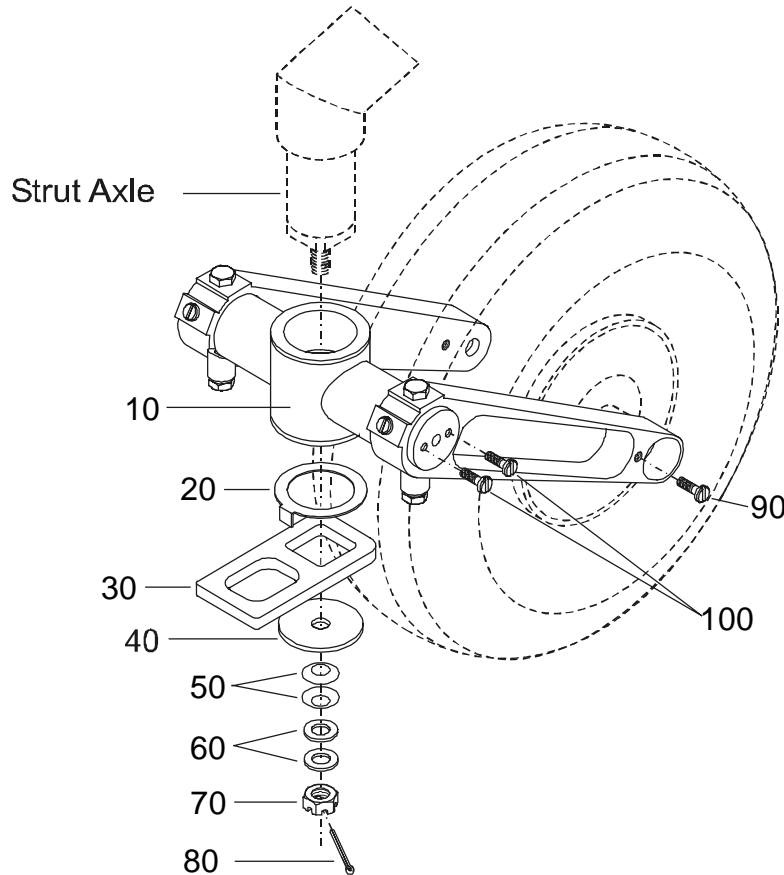

Figure 1

ITEM	PART NUMBER	DESCRIPTION
10	20-3220-08-00.....	Fork Assembly, Nose Landing Gear
20	20-3220-00-20.....	Washer, Thrust, Stator
30	20-3220-00-23.....	Stop Plate, Steering
40	20-3220-00-17.....	Spacer, Lower
50	680-221.....	Spring, Belleville (Spae-Naur)
60	AN960-616.....	Washer, Flat
70	AN310-6.....	Nut, Castellated (Pivot Nut)
80	MS24665-285.....	Pin, Cotter
90	MS35207-281.....	Screw, Machine, Panhead
100	MS51958-64.....	Screw, Machine, Panhead

Table 1

SERVICE BULLETIN



Service Bulletin No.: DA20-32-02 Rev 0

Date Issued: 8 January, 1999

Title: Nose Gear Fork, Fatigue

Page: 5 of 6

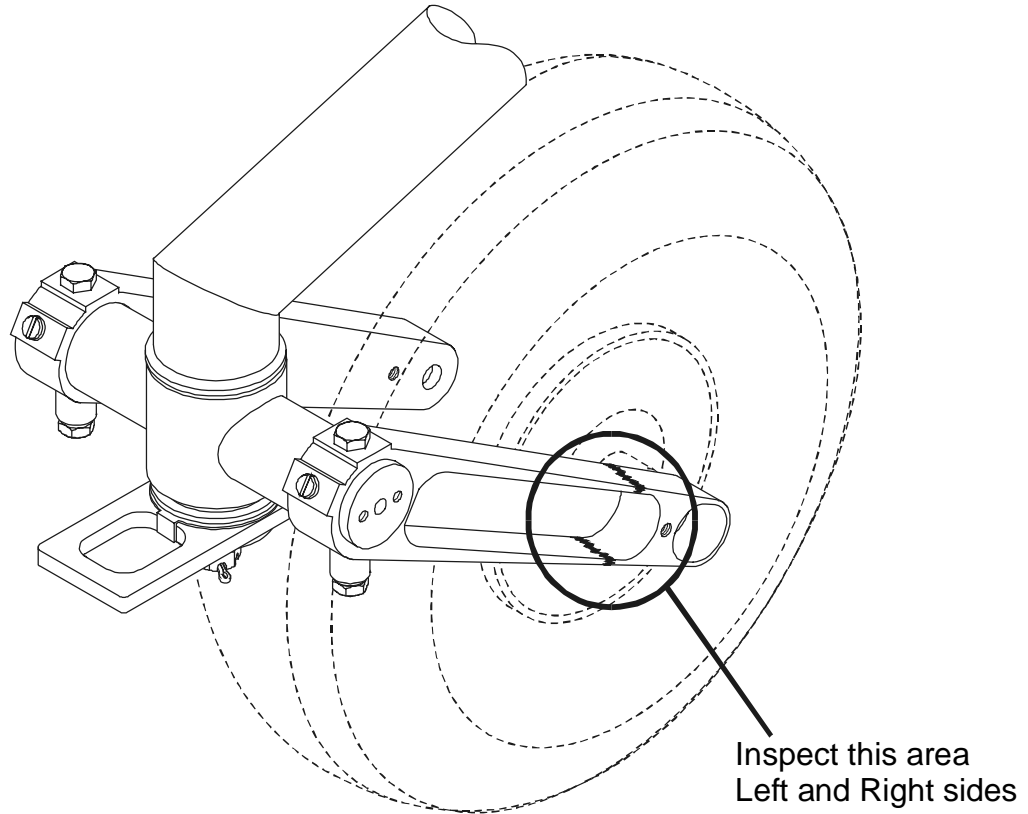
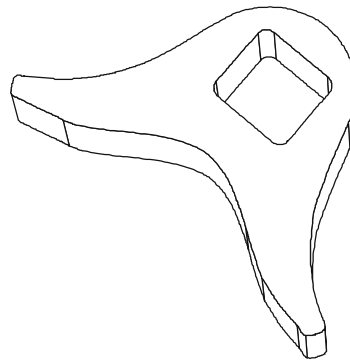

Figure 2



P/N 20-3220-00-18
Steering Stop Plate
Fitted to some aircraft.

Figure 3

SERVICE BULLETIN



Service Bulletin No.: DA20-32-02 Rev 0

Date Issued: 8 January, 1999

Title: Nose Gear Fork, Fatigue

Page: 6 of 6

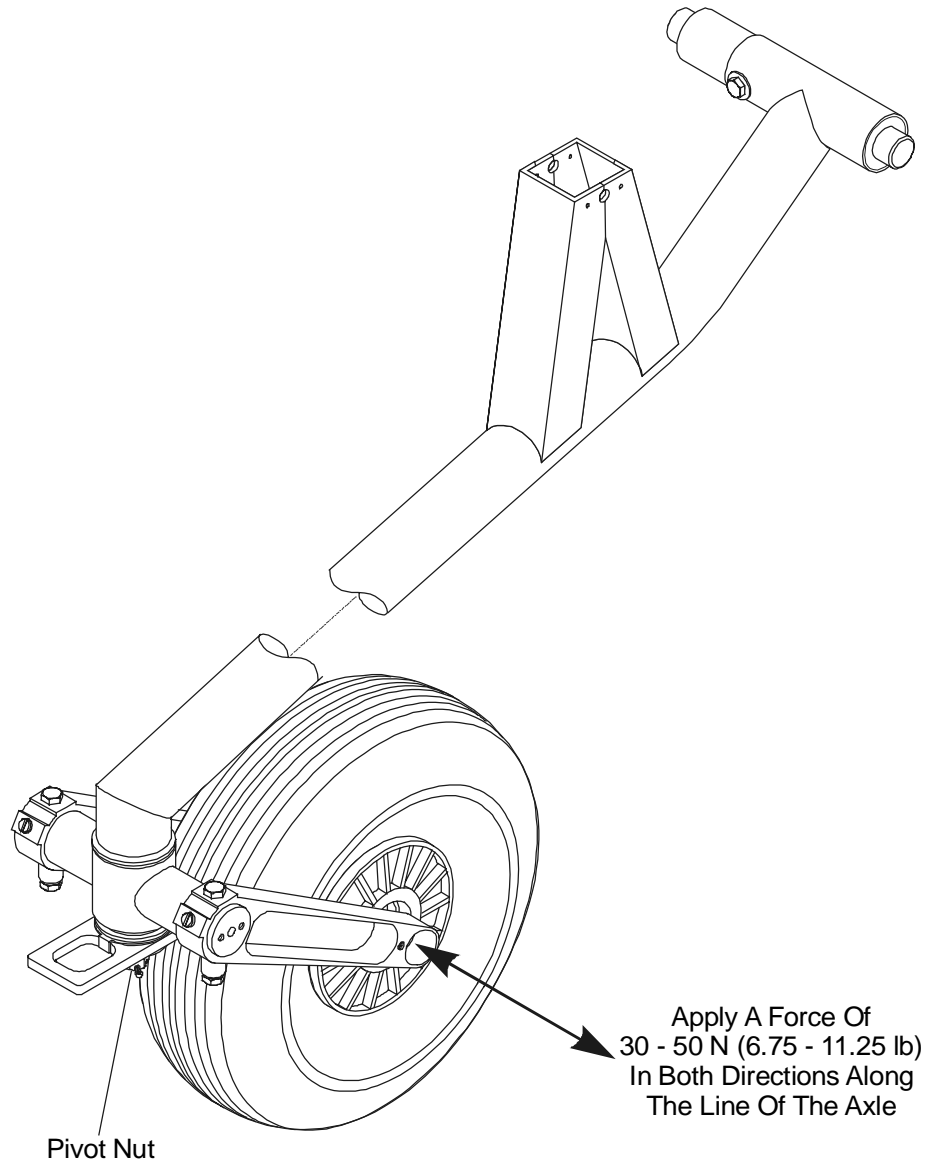

Figure 4