

SERVICE BULLETIN



Service Bulletin No.: DA20-32-05 Rev. 1

Date Issued: July 13, 2010

Title: Replacement of Steel MLG Struts
with Aluminum MLG Struts

Page: 1 of 9

-
1. **ATA Code:** 3210
2. **Effectivity:** DA20-A1 aircraft, Serial Numbers 10002 to 10234.
3. **General:** This Service Bulletin provides the procedures necessary to replace the Steel Main Landing Gear (MLG) struts installed on the aircraft with Aluminum MLG struts.
- NOTE: The steel MLG struts P/Ns 20-3210-00-01 LH, 20-3210-00-02 RH must be replaced as a set with the aluminum MLG struts P/N 22-3211-00-01 LH and P/N 22-3211-00-02 RH.
- Revision 1 changes items 43 and 44 in the Parts Listing to be measured in degrees rather than inches and removes Item 45 (20-3210-10-00 - Dust, Boot Assembly) from Figure 2, Sheet 1 and the Parts Listing. The Dust, Boot Assembly can be re-used.
4. **Compliance:** Optional.
5. **Approval:** Engineering data referenced or contained in this service bulletin is approved as part of the type design.
6. **Labour:** Approximately 6 hours will be required to accomplish this Service Bulletin.
- This estimate is for direct labour performed by a technician and it does not include setup, planning, familiarization, cure time, part fabrication or tool acquisition.*
7. **Material:** The items required to install this Service Bulletin, listed in the Aluminum MLG - Parts Listing, can be ordered as Kit DA20-32-05-AMK0.
8. **Special Tools:** N/A.
9. **References:** DA20-A1 Aircraft Maintenance Manual, Document # DA201-A1.

10. Accomplishment Instructions

- 10.1 Put the aircraft on jacks. Refer to AMM # DA201-A1 Chapter 07-20.
- 10.2 Remove the steel MLG strut (P/N 20-3210-00-01) LH and the steel MLG strut (P/N 20-3210-00-02) RH.
Refer to AMM # DA201-A1 Chapter 32-10.
- 10.3 Install the aluminum MLG strut (P/N 22-3211-00-01) LH.
Refer to Figure 1, Figure 2, and the Parts Listing for the aluminum MLG.
 - 10.3.1 Examine the spar bridge in the area of the main gear mounting locations. Look specifically for damage to the GFRP structure.
Refer to AMM # DA201-A1 Chapter 51-10 for GFRP inspection procedures.
 - 10.3.2 Put the new strut in position.
 - 10.3.3 At the outer mounting location, put inserts in position above and below the strut.
 - 10.3.4 Apply grease to the brass shims used on the forward and aft side of the strut.
Use MIL-G-3545 grease.
 - 10.3.5 Install the retaining bar. Torque the mounting nut to 20 Nm (177 lb.in.).
 - 10.3.6 At the inner mount location, install the parts in the following order:
Inner bolt, inner mount, 2 belleville spring washers, plain washer, strut, convex washer, concave washer, plain washer and nut.

NOTE: Install the 2 belleville spring washers with the concave sides facing each other.
If necessary, install up to 2 plain washers between the belleville spring washers and the inner mount to make the airplane level.
Apply grease to the inner mounting bolt prior to installation. Use MIL-G-3545 grease.

NOTE: It may be necessary to shorten the LHS inner mount bolt to clear the flap actuator. If it is shortened, deburr and seal the end with Dinitrol to stop corrosion.
 - 10.3.7 Tighten the nut on the inner mounting bolt until the belleville washers are compressed to a height of 4.0mm (+0.5mm, -0mm)(0.16in (+0.02in, -0in)).

-
- 10.3.8 Connect the bonding wire to the strut. If you install a bonding terminal on a new strut, remove the surface protection where the terminal will attach. Varnish the area with NYCOTE 7-11.
 - 10.3.9 Install the axle, torque-plate and fairing mount.
Install the 4 bolts that attach to the axle.
Torque to 13.6 – 15.8 Nm (120-140 lb.in.).
 - 10.3.10 Attach the brake line and brake line bracket to the strut.
 - 10.3.11 Install the brake caliper. Refer to AMM # DA201-A1 Chapter 32-40.
 - 10.3.12 Install the inner axle seal.
 - 10.3.13 Install the wheel. Refer to AMM # DA201-A1 Chapter 32-40.
 - 10.3.14 Install the back-plate to the brake caliper.
 - 10.4 Repeat steps 10.3.1 to 10.3.14 to install the aluminum MLG strut (P/N 22-3211-00-02) RH.
Refer to Figure 1, Figure 2 and the Parts Listing for the aluminum MLG.
 - 10.5 Lower the aircraft off the jacks. Refer to AMM # DA201-A1 Chapter 07-20.
 - 10.6 Do a test for correct adjustment of the landing gear. Add shims if required.
Refer to AMM # DA201-A1 Chapter 32-10.
 - 10.7 (Optional) Install the wheel fairing. Install the outer bolt. Install the 2 screws on the inboard side.
 - 10.8 Make a log book entry that this Service Bulletin has been incorporated.

SERVICE BULLETIN



Service Bulletin No.: DA20-32-05 Rev. 1

Date Issued: July 13, 2010

Title: Replacement of Steel MLG Struts
with Aluminum MLG Struts

Page: 4 of 9

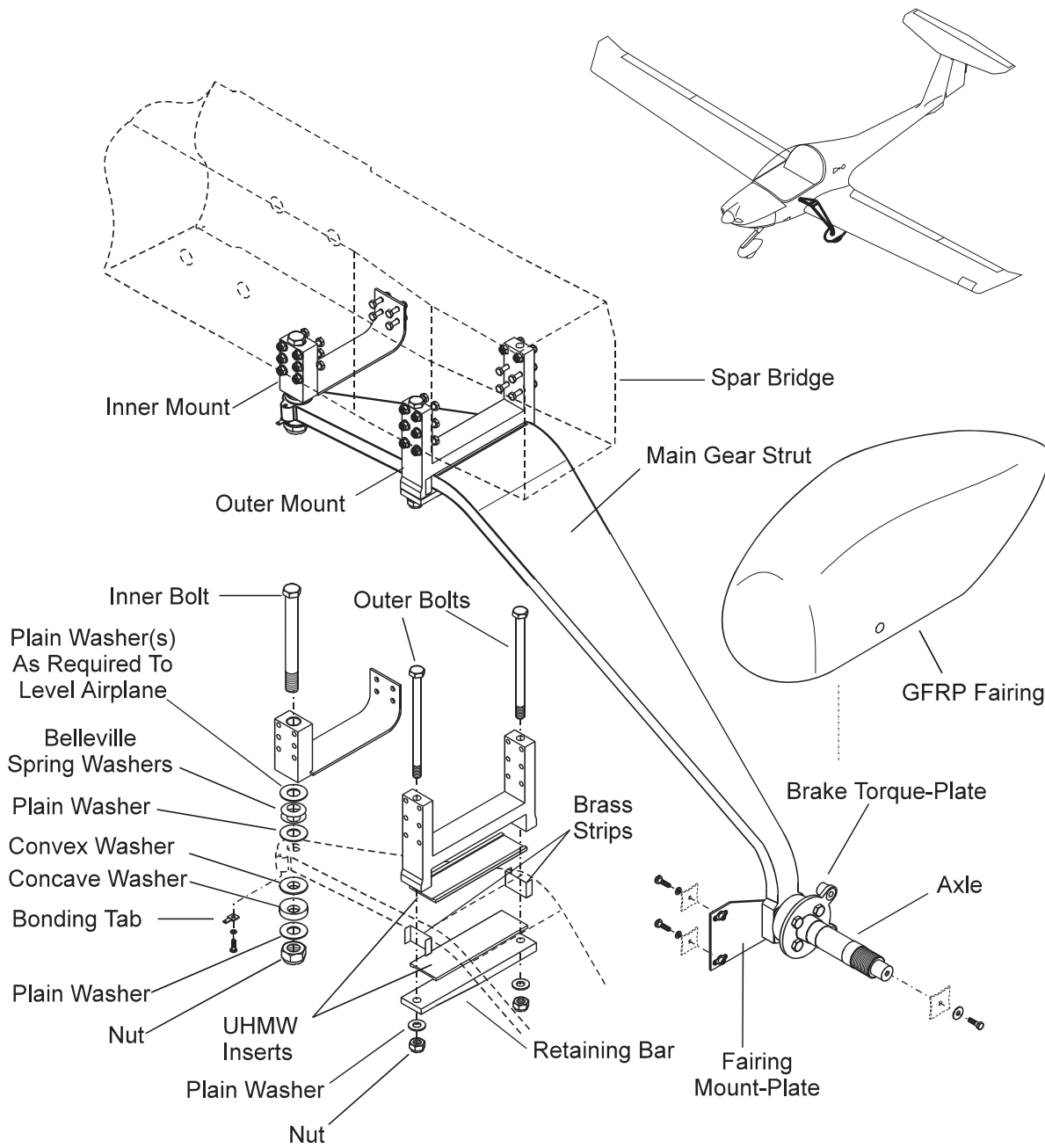

Figure 1 - Aluminum Main Landing Gear - Strut Installation

SERVICE BULLETIN



Service Bulletin No.: DA20-32-05 Rev. 1

Date Issued: July 13, 2010

Title: Replacement of Steel MLG Struts
with Aluminum MLG Struts

Page: 5 of 9

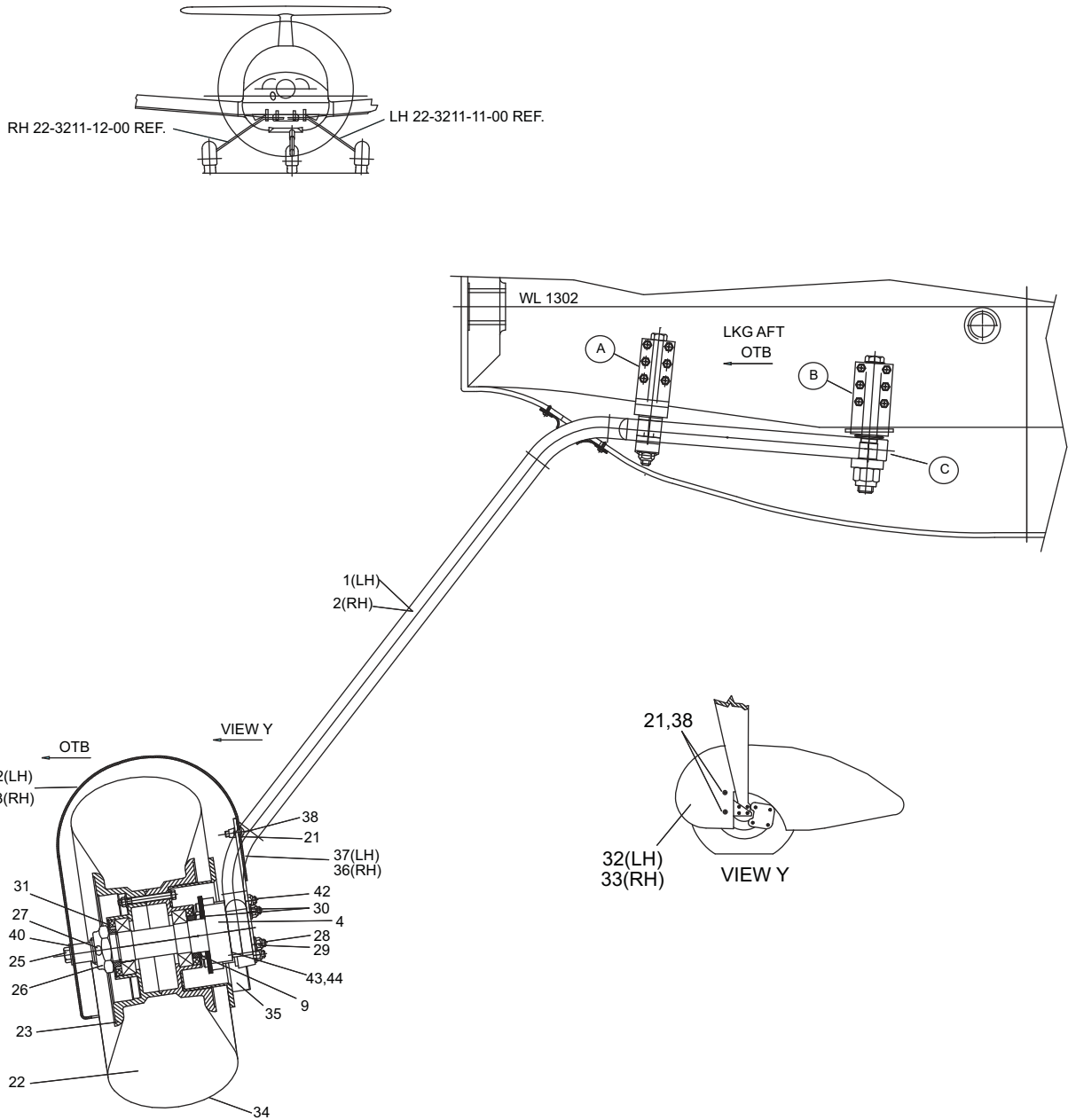

Figure 2, Sheet 1 - Aluminum Main Landing Gear

SERVICE BULLETIN



Service Bulletin No.: DA20-32-05 Rev. 1

Date Issued: July 13, 2010

Title: Replacement of Steel MLG Struts
with Aluminum MLG Struts

Page: 6 of 9

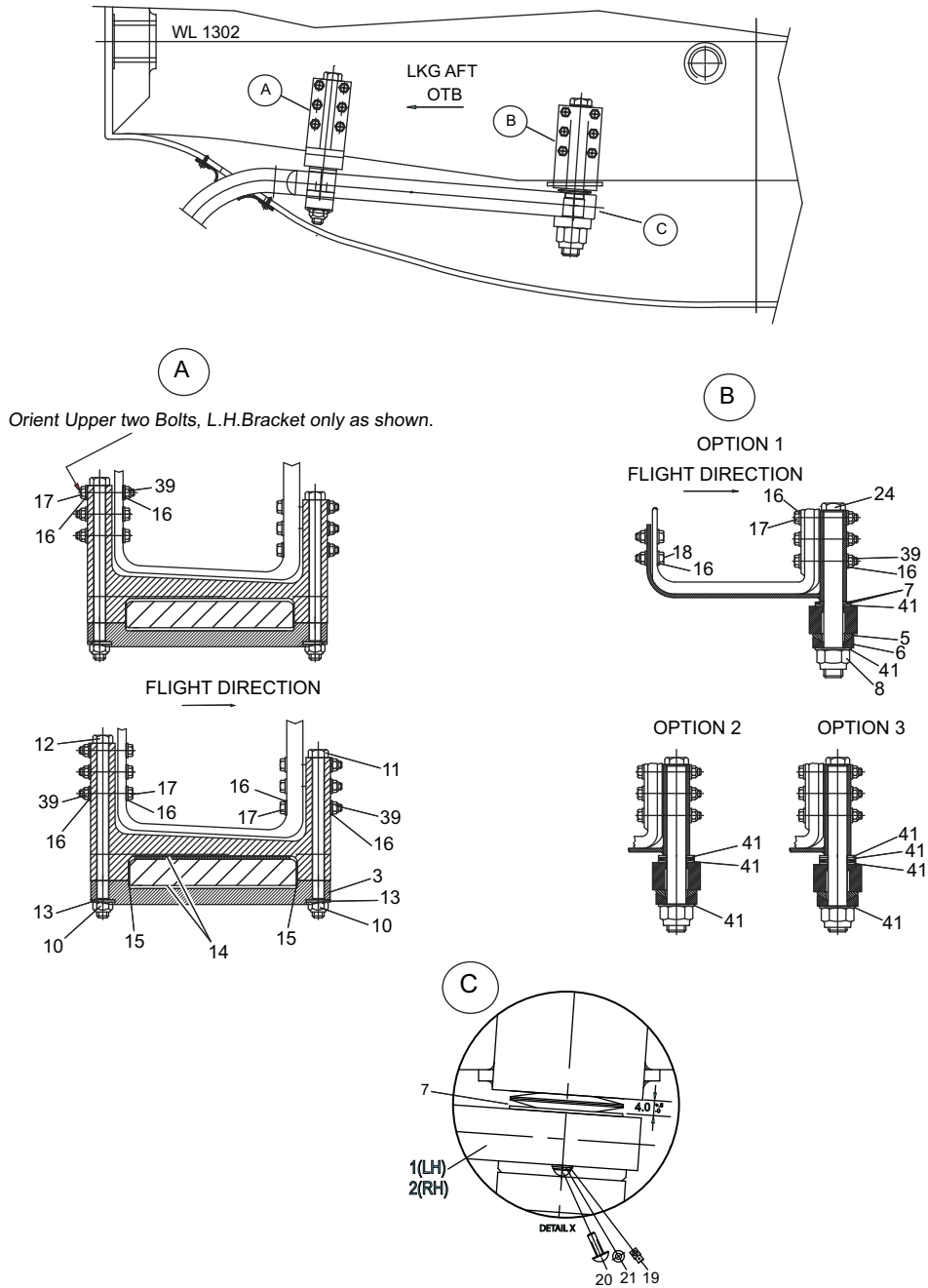

Figure 2, Sheet 2 - Aluminum Main Landing Gear

SERVICE BULLETIN



Service Bulletin No.: DA20-32-05 Rev. 1

Date Issued: July 13, 2010

Title: Replacement of Steel MLG Struts
with Aluminum MLG Struts

Page: 7 of 9

Aluminum MLG - Parts Listing (Figure 2)

Fig Item	Part Number	Nomenclature	Units Per Assy
1	22-3211-00-01	Strut, MLG, LH	1
2	22-3211-00-02	Strut, MLG, RH	1
3	22-3210-00-04	Bar, Outer, MLG (See NOTE 1)	2
4	20-3210-07-00	Axel, MLG (See NOTE 1)	2
5	20-3210-00-06	Washer, Convex	2
6	20-3210-00-07	Washer, Concave	2
7	DS-180	Spring, Belleville	4
8	172-020	Locknut, L9 Stover	2
9	20-3210-00-21	Seal, Inner Axel	2
10	MS21044N6	Nut, Self-Locking	4
11	AN6-52A	Bolt, Hex	2
12	AN6-56A	Bolt, Hex	2
13	AN960-C616	Washer, Plain	4
14	20-3210-00-14	Insert, (Top/Bottom)	4
15	22-3210-00-13	Insert, (Side)	4
15A	22-3210-00-16	Insert, (Side)	4
16	AN960 C416	Washer, Plain (See NOTE 1)	88
17	AN4-20A	Bolt, Hex Head (See NOTE 1)	36
18	AN4-6A	Bolt, Hex Head (See NOTE 1)	8
19	61365-1	Terminal	2
20	MS51958-60	Screw	2
21	AN960 C10	Washer, Plain	6
22	5.00-5 TR67	Inner Tube (See NOTE 1)	2
23	40-78E	Wheel Assembly (See NOTE 1)	2
24	329-239	Bolt, Hex Head L9	2
25	AN5-4A	Bolt, Hex (See NOTE 1)	2
26	AN320-18	Nut, Castellated (See NOTE 1)	2
27	MS 24665-428	Cotter Pin (See NOTE 1)	2

SERVICE BULLETIN



Service Bulletin No.: DA20-32-05 Rev. 1

Date Issued: July 13, 2010

Title: Replacement of Steel MLG Struts
with Aluminum MLG Struts

Page: 8 of 9

Fig Item	Part Number	Nomenclature	Units Per Assy
28	AN5-24A	Bolt, Hex	6
29	MS21044N5	Nut, Self-Locking	8
30	AN960 C516	Washer, Plain	16
31	20-3210-00-12	Spacer (See NOTE 1)	2
32	22-3210-05-00	Fairing, MLG, LH (See NOTE 1)	1
33	22-3210-06-00	Fairing, MLG, RH (See NOTE 1)	1
34	380x150/15x6.00 StPR	Tire (See NOTE 1)	2
35	30-9D	Brake Assembly (See NOTE 1)	2
36	20-3210-04-00	Bracket, MLG, Fairing, RH (See NOTE 1)	1
37	20-3210-03-00	Bracket, MLG, Fairing, LH (See NOTE 1)	1
38	MS51958-64	Screw, Brazier Head (See NOTE 1)	4
39	MS21044N4	Nut, Self-Locking (See NOTE 1)	44
40	NAS1515H5H	Washer, Nylon (See NOTE 1)	2
41	AN960C1016	Washer, Plain	2
42	AN5-23A	Bolt, Hex	2
43	20-3210-00-16	Shim, 1 degree	AR
44	20-3210-00-17	Shim, 2 degrees	AR

NOTE 1: Item is not included in the Parts Kit DA20-32-05-AMK0.

SERVICE BULLETIN



Service Bulletin No.: DA20-32-05 Rev. 1

Date Issued: July 13, 2010

Title: Replacement of Steel MLG Struts
with Aluminum MLG Struts

Page: 9 of 9

-
- 11. Weight and Balance:** Perform weight and balance in accordance with the maintenance manual, AMM # DA201-A1 Chapter 08.
- 12. Availability:** Contact Diamond Aircraft.
- 13. Electrical Load Data:** There is no impact to the electrical load.
- 14. Credit:** None.

To obtain satisfactory results, procedures specified in this service bulletin must be accomplished in accordance with accepted methods and current government regulations. Diamond Aircraft Industries Inc. cannot be responsible for the quality of work performed in accomplishing the requirements of this service bulletin. Diamond Aircraft reserves the right to void continued warranty coverage in the area affected by this service bulletin if it is not incorporated.

If you no longer own the aircraft to which this service bulletin applies, please forward it to the current owner and send the name of the current owner to Diamond Aircraft Industries Inc. at the address below.

Diamond Aircraft Industries Inc. 1560 Crumlin Sideroad, London, Ontario, Canada N5V 1S2

Customer Support: Phone: (519) 457-4041 Fax: (519) 457-4045 E-mail: custsupp@diamondair.com
Technical Publications: Phone: (519) 457-4030 Ext. 3173 E-mail: techpubs@diamondair.com