

ALERT SERVICE BULLETIN



Service Bulletin No.: DA20-55-02-A, Rev. 0

Date Issued: March 9, 1996

Title: Mount, Forward Attachment, Horizontal Stabilizer

Page: 1 of 3

1. **ATA Code:** 5510
2. **Effectivity:** DA 20 Katanas, S/N 10002 to 10042 inclusive
3. **General:** This Bulletin describes a special visual inspection of the forward stabilizer mount assembly to ensure correct installation.
4. **Compliance:** Prior to next flight.
5. **Approval:** Engineering data referenced or contained in this bulletin is Transport Canada approved.
6. **Labor:** 0.5 man-hours
7. **Material:** None
8. **Special Tools:** None
9. **References:** DA20 Katana Parts Catalog, Page I-53-10, Item #5.
Attached Figure 1.

10. Accomplishment Instructions

- 10.1 Deflect rudder to either left or right stop and hold.
- 10.2 Use a flashlight and inspection mirror to inspect the forward stabilizer mount assembly through the rudder balance cut out in the vertical stabilizer for the presence of the retaining ring (ref. DA20 Parts Catalog, attached figures 1 and 2).
Note: The retaining ring may be partially painted and difficult to distinguish from the mount plate. Positively ensure proper location of the retaining ring by identifying the snap ring plier holes.
- 10.3 If stabilizer mount is assembled correctly, no further action is required.
- 10.4 If stabilizer mount is assembled incorrectly (as shown on figure 3), remove horizontal stabilizer in accordance with the Maintenance Manual, remove snap ring, remove bushing and reassemble in correct sequence.
Note: Do Not remove mount plate from stabilizer as it is bonded in place.
- 10.5 Please report your findings to Diamond Aircraft - Customer Support .
(Tel. 1-800-462-3820, Fax 1-519-457-4037).

ALERT SERVICE BULLETIN



Service Bulletin No.: DA20-55-02-A, Rev. 0

Date Issued: March 9, 1996

Title: Mount, Forward Attachment, Horizontal Stabilizer

Page: 2 of 3

11. Weight and Balance: N/A

12. Electrical Load Data: N/A

13. Credit: None

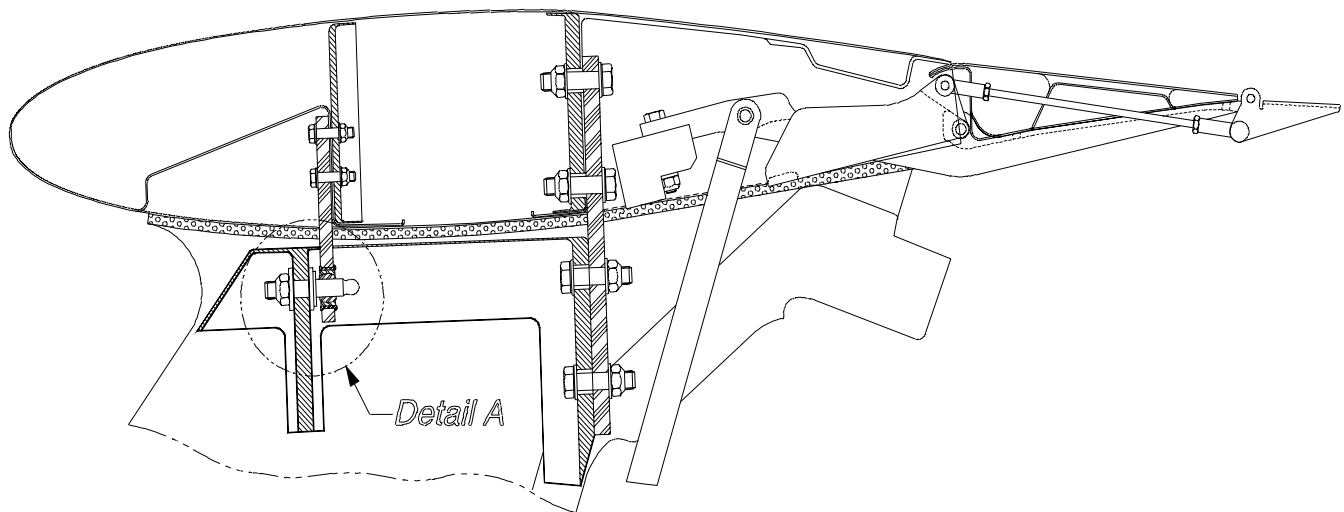

Figure 1. Horizontal Stabilizer Forward Mount Attachment (Ref. Detail A).

To obtain satisfactory results, procedures specified in this service information letter must be accomplished in accordance with accepted methods and current government regulations. Diamond Aircraft Industries Inc. cannot be responsible for the quality of work performed in accomplishing the requirements of this service information letter.

Diamond Aircraft Industries Inc. 690 Crumlin Sideroad, London, Ontario, Canada N5V 1S2
Phone: (519) 457-4000 Fax: (519) 457-4037

COPYRIGHT 1995

ALERT SERVICE BULLETIN



Service Bulletin No.: DA20-55-02-A, Rev. 0

Date Issued: March 9, 1996

Title: Mount, Forward Attachment, Horizontal Stabilizer

Page: 3 of 3

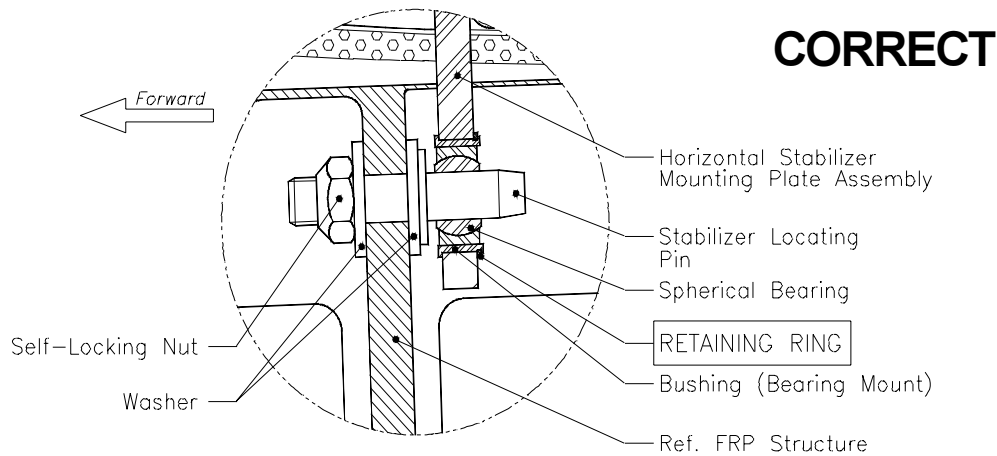

Figure 2. Detail A - Correct Retaining Ring Installation.

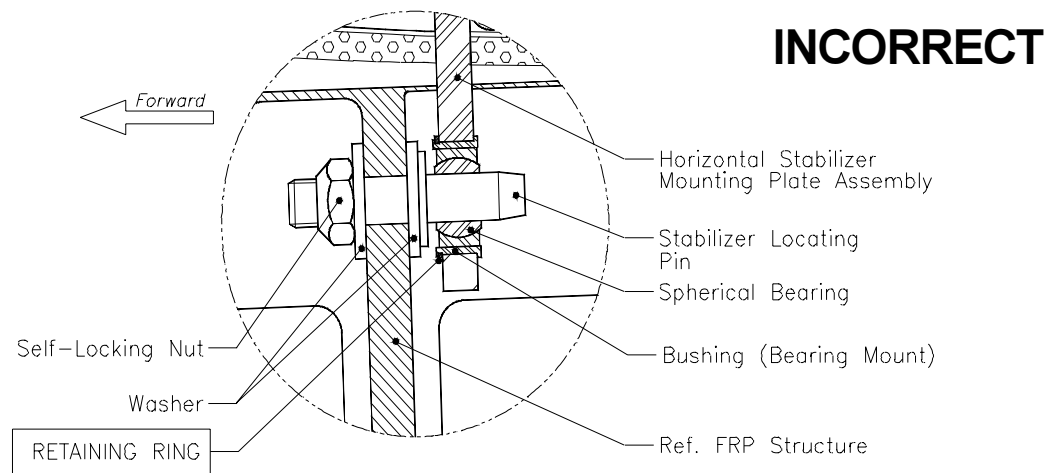

Figure 3. Detail A - Incorrect Retaining Ring Installation.