



DA42-VI

SMART ENHANCEMENTS AND REFINED FEATURES
DESIGNED FOR MODERN TRAINING, OPERATIONAL
PRECISION, AND EVERYDAY RELIABILITY.



The DA42-VI pairs single engine fuel burn with the confidence of a twin, offering exceptional performance for up to four people. Beloved by private pilots, business flyers, and flight schools.

REACH NEW HEIGHTS.

[#WeFlyDiamondAircraft](#)

BUILT FOR EFFICIENCY.

The DA42-VI benefits from a series of carefully considered refinements which focus on improving usability, efficiency, and day-to-day operation—both in training environments and private use. From cockpit to cabin, each detail has been fine-tuned

with purpose. The result: a well-balanced aircraft that continues to deliver consistent performance, operational efficiency, and a modern flying experience—now with even greater attention to the details that matter in everyday use.



scan to learn more about our DA42-VI

TECHNOLOGY & AVIONICS

SAFETY



DIGITAL STANDBY INSTRUMENTS

(mid-Continent MD-302 as a standard feature) **Backup you can trust.** The DA42 now comes standard with a Mid-Continent digital standby instrument delivering cleaner information, a more modern cockpit experience and reduced maintenance requirements.

LED LANDING TAXI LIGHTS

See more. Fly safer. Advanced LED technology delivers brighter, whiter light with lower power use, improving runway visibility and extending service life. The WAT Prodigy lens provides up to three times the brightness of standard LED landing lights.

READY TO PERFORM.

CONVENIENCE & AESTHETICS



FOLDING MIDDLE ARMREST

(including 2x USB-C ports (100W) for passengers) **Enhanced comfort.** A thoughtfully integrated armrest with two rear 100 W USB-C charging ports keeps personal devices powered, enhancing comfort and focus throughout the flight.



ERGONOMIC LEATHER PILOT-STICK

For pilots who value the details. An elegant upgrade crafted for pilots demanding comfort, control and cockpit aesthetics.



QUICK FIX HARNESS

Secure. Simple. Effortless. The redesign baggage harness combines reliable load security with a new, easier locking mechanism for everyday convenience.



COMFORT PLUS PACKAGE

Comfort elevated. The Diamond Comfort-Plus Package enhances every flight with premium comfort and smart features, including high-power USB-C charging and integrated cable management for a cleaner, more convenient cabin

COMFORT & AESTHETICS



PAX ROW SEATING COMFORT

More room. More comfort for passengers. The repositioned backrest of the passengers row and a contoured seat shell create a more relaxed posture, while a curved headliner adds 5 cm of extra headroom for enhanced passenger comfort.

DA42 SHADOW EDITION

Redefined presence. The Shadow Package enhances the DA42 with black exterior accents and anthracite interior finishes, complemented by black seals and hardware for a sleek, refined look.

SMART & CONVENIENCE



ILLUMINATED HIGH-POWER USB-C

Stay connected. High-power, fast-charging USB-C ports ensure continuous connectivity for pilots and passengers, while offering the flexibility to power additional devices like Starlink.



INTEGRATED CHARGING CABLE HOLDER

Clean and convenient. Stay organized and enjoy a cleaner, more efficient space.

TECHNICAL SPECIFICATIONS

BUILT FOR EFFICIENCY. READY TO PERFORM.



You want to know more?
scan & click

POWER PLANT

Engine	2 × Austro Engine AE 300 turbocharged common-rail injected 2.0 liter diesel engine with 168 HP and EECU single lever control system
Propeller	2 × MT propeller MTV-6-R-C-F/CF 190-69 3-blade constant speed propeller
Fuel grades	Jet A-1, Jet A, TS-1 & RT (Russia, Ukraine), No. 3 Jet Fuel (China), JP-8



Consumption 50% total
33 lt/h or 8.8 gal/h



Max. Cruise Speed
352 km/h or 190 kts



Max. Altitude
5,488 m or 18,000 ft



Useful Load
579 kg or 1,276 lbs

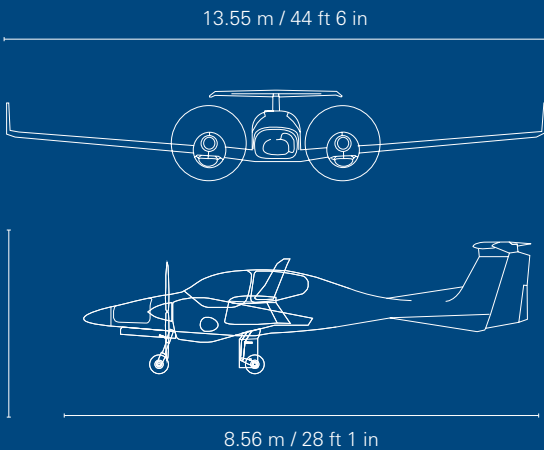

DIMENSIONS / MASS / LOADING

Max. take-off mass: 4,407 lbs (1,999 kg)

Empty weight without options: 3,131 lbs (1,420 kg)

Max. useful load: 1,276 lbs (579 kg)

Fuel capacity total (usable fuel) 289 lt / 231 kg
76.4 US gal / 512 lbs

main tank 189 lt / 151 kg | 50.0 US gal / 333 lbs
auxiliary tank 100 lt / 80 kg | 26.4 US gal / 176 lbs

NORTH & SOUTH AMERICA, AUSTRALIA, NEW ZEALAND

1560 Crumlin Sideroad,
London, ON, Canada, N5V1S2
Phone: +1 800 268 4001
sales-canada@diamondaircraft.com

EUROPE, MIDDLE EAST, AFRICA, ASIA (HQ)

N. A. Otto-Strasse 5,
2700 Wiener Neustadt, Austria
Phone: +43 2622 26700
sales-austria@diamondaircraft.com

CHINA

Wanfeng Airpark, Dashiju Town
Xinchang County, Zhejiang
Province | P. R. China

All specifications, weights, representations, colors, equipment, use of materials and model references provided herein are for purely illustrative purposes and legally non-binding, subject to alterations and not warranted or guaranteed to be true or accurate. Actual useful load will vary depending on options installed on the aircraft. Any and all information given in this brochure cannot exempt the person operating the aircraft to use actual data for flight planning. The aircraft and/or product, and the chosen optional equipment (if any) shall meet exclusively the characteristics and specifications as defined and agreed in the written agreement with Diamond Aircraft Group. Referenced Diamond Aircraft trademarks are owned by Diamond Aircraft Industries GmbH or its subsidiaries. All other brands, product names, company names, trademarks and service marks are the properties of their respective owners. All rights reserved. ©2026, Diamond Aircraft Industries GmbH. For additional information on Diamond Aircraft and its products please visit www.diamondaircraft.com