



DA62

ENGINEERED TO ENHANCE SAFETY, CAPABILITY, AND ON-BOARD EXPERIENCE—ACROSS EVERY PHASE OF FLIGHT.



The world's top selling twin, it carries up to seven people farther and faster than anything else - delivering extraordinary fuel efficiency and twin engine safety.

GO ABOVE AND BEYOND.

#WeFlyDiamondAircraft

ADVANCED BY DESIGN.

the DA62 continues to define the standard in its class—combining twin-engine performance, exceptional efficiency, and advanced technology in a versatile, modern aircraft platform. With the latest feature updates, the aircraft evolves further, introducing enhancements that strengthen safety, expand system capability, and refine

both cockpit and cabin experience. From advanced traffic and weather systems to intelligent connectivity and refined interior details, these enhancements elevate every aspect of the aircraft—ensuring the DA62 remains ready to meet the demands of modern aviation with precision, reliability, and performance.



scan to learn more about our DA62

SMART & CONVENIENCE

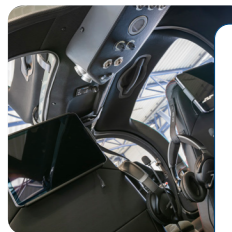

DISPLAY MOUNT PROVISIONS

Entertainment to go. Integrated display mounts elevate passenger experience with hands-free comfort, effortless in-flight entertainment and a premium touch to every journey.



ILLUMINATED HIGH-POWER USB-C

Stay connected. High-power, fast-charging USB-C ports ensure continuous connectivity for pilots and passengers, while offering the flexibility to power additional devices like Starlink.

SMART & SAFETY

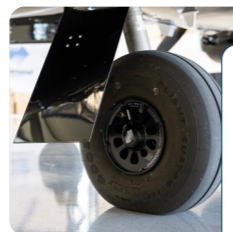

BERINGER BRAKES INCL. SENS AIR

Elevate your pre-flight checks. Beringer brakes with SensAIR provide real-time tire pressure and temperature monitoring with smartphone alerts for added peace of mind.



MAGNETIC HEADSET HOLDERS

Effortless storage. Magnetic headset holders provide effortless storage while maintaining a clean cockpit & a premium finish.

READY FOR MORE.

SAFETY

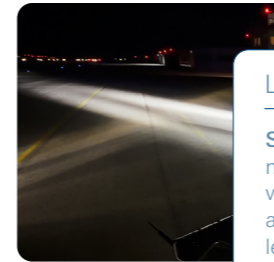

LED LANDING TAXI LIGHTS

See more. Fly safer. Advanced LED technology delivers brighter, whiter light with lower power use, improving runway visibility and extending service life. The WAT Prodigy lens provides up to three times the brightness of standard LED landing lights.



GARMIN GTS 800

Confidence in Busy Airspace. Integrated with the Garmin NXi, the GTS 800 delivers advanced traffic awareness with clear visual and voice alerts. It helps pilots quickly detect and avoid nearby aircraft, enhancing safety in high-density airspace.



GARMIN GWX 8000

All around weather awareness made simple. Advanced Garmin weather radar with StormOptix technology automatically adapts to 3D storm cells, delivering clear, high-definition visuals. Enhanced with turbulence detection and predictive alerts for lightning and hail, it helps pilots better understand and avoid severe weather.

CONVENIENCE & AESTHETICS



DOOR CLOSING STRAP (PILOT & CO-PILOT)

Small detail. Premium design. The magnetic door closing strap is easy and quick to use. Crafted from high-quality leather adding additional elegance to the cabin while seamlessly integrated with the aircraft interior.



ERGONOMIC LEATHER PILOT-STICK

For pilots who value the details. An elegant upgrade crafted for pilots demanding comfort, control and cockpit aesthetics.



CUSTOMIZED LUGGAGE COLLECTION

Tailored to Your Diamond. Built to travel. Each piece of the Diamond Customized Luggage Collection precisely shaped to the aircraft's baggage geometry, this custom luggage maximizes space and loads effortlessly, finished in luxurious materials that perfectly match Diamond's interior design.

TECHNICAL SPECIFICATIONS

The DA62 is Diamond's ultimate flying machine: where speed, style, space, and safety come together.



You want to know more?
scan & click

POWER PLANT

Engine	2x AUSTRO ENGINE AE330 180HP turbocharged common-rail direct injected 2.0 liter Jet A-1 engine with FADEC single lever power control (SLPC)
Propeller	2x MT propeller MTV-6-R-C-F/CF 194-80 3-blade constant speed propeller
Fuel grades	Jet A-1, Jet A, TS-1, RT, No. 3 Jet Fuel, JP-8



Consumption 60% total
44.7 lt/h or 11.8 gal/h



Max. Cruise Speed
356 km/h or 192 kts



Max. Altitude
6,096 m or 20,000 ft



Useful Load
702 kg or 1,545 lbs

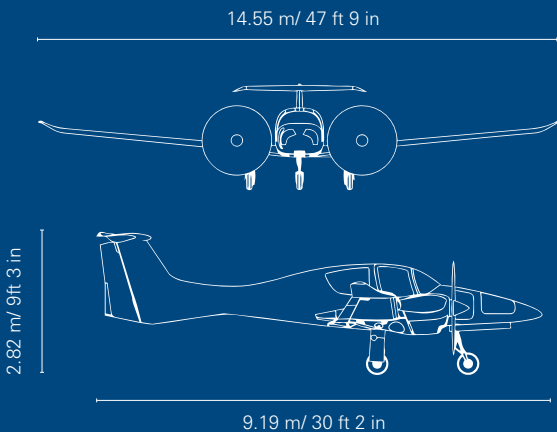

DIMENSIONS / MASS / LOADING

Maximum Take-Off Mass: 5,071 lbs (2,300 kg)

Empty Mass: 3,523 lbs (1,598 kg)

Maximum useful load: 1,545 lbs (702 kg)

Fuel capacity total (usable fuel): 327 l / 261 kg
(86.4 US gal / 576 lbs)

main tank: 189 l / 151 kg (50 US gal / 333 lbs)

auxiliary tank: 138 l / 110 kg (36.4 US gal / 243 lbs)

**NORTH & SOUTH AMERICA,
AUSTRALIA, NEW ZEALAND**
1560 Crumlin Sideroad,
London, ON, Canada, N5V1S2
Phone: +1 800 268 4001
sales-canada@diamondaircraft.com

**EUROPE, MIDDLE EAST,
AFRICA, ASIA (HQ)**
N. A. Otto-Strasse 5,
2700 Wiener Neustadt, Austria
Phone: +43 2622 26700
sales-austria@diamondaircraft.com

CHINA
Wanfeng Airpark, Dashiju Town
Xinchang County, Zhejiang
Province | P. R. China

All specifications, weights, representations, colors, equipment, use of materials and model references provided herein are for purely illustrative purposes and legally non-binding, subject to alterations and not warranted or guaranteed to be true or accurate. Actual useful load will vary depending on options installed on the aircraft. Any and all information given in this brochure cannot exempt the person operating the aircraft to use actual data for flight planning. The aircraft and/or product, and the chosen optional equipment (if any) shall meet exclusively the characteristics and specifications as defined and agreed in the written agreement with Diamond Aircraft Group. Referenced Diamond Aircraft trademarks are owned by Diamond Aircraft Industries GmbH or its subsidiaries. All other brands, product names, company names, trademarks and service marks are the properties of their respective owners. All rights reserved. ©2026, Diamond Aircraft Industries GmbH. For additional information on Diamond Aircraft and its products please visit www.diamondaircraft.com